

12419  
03

---

**AMENDED AND RESTATED ELECTRIC VEHICLE SHARING CONCESSION  
AGREEMENT**

**DATED AS OF THE 31ST DAY OF MARCH, 2015**

**BY AND BETWEEN**

**THE CITY OF INDIANAPOLIS, INDIANA**

**AND**

**BLUEINDY, LLC.**

---

TABLE OF CONTENTS

|   | <u>Page</u> |
|---|-------------|
| ARTICLE I. DEFINITIONS .....  | 2           |
| Section 1.01. Definitions.....  | 2           |
| ARTICLE II. EXCLUSIVE RIGHT; INFRASTRUCTURE IMPROVEMENTS.....                   | 8           |
| Section 2.01. Exclusive Right.....  | 8           |
| Section 2.02. Designation of Representatives.....                               | 9           |
| Section 2.03. Services by the Company.....                                      | 10          |
| Section 2.04. Implementation.....   | 12          |
| Section 2.05. Locations.....  | 18          |
| Section 2.06. Towing.....   | 20          |
| Section 2.07. Vehicle Type.....   | 21          |
| ARTICLE III. MAINTENANCE & REPAIR.....  | 21          |
| Section 3.01. The City's Repairs.....   | 21          |
| Section 3.02. The Company's Replacement & Maintenance; Access to Locations..... | 21          |
| Section 3.03. Encumbrances.....   | 22          |
| ARTICLE IV. TERM, TERMINATION, & GUARANTY.....                                  | 22          |
| Section 4.01. Term.....   | 22          |
| Section 4.02. Rights of Termination.....  | 22          |
| Section 4.03. Reimbursement for Early Termination & Guaranty.....               | 23          |
| Section 4.04. Location Fixtures.....  | 23          |
| Section 4.05. Effect of Termination.....  | 24          |
| Section 4.06. Offset of Early Termination Payment.....                          | 24          |
| ARTICLE V. OTHER AGREEMENTS & COVENANTS.....                                    | 25          |
| Section 5.01. Name of the Services; Publicizing Services; Advertising.....      | 25          |
| Section 5.02. Profit Sharing & Rate Mitigation.....                             | 25          |
| Section 5.03. Reporting Requirements.....                                       | 29          |
| Section 5.04. Insurance.....  | 30          |
| Section 5.05. Utilities.....  | 30          |
| Section 5.06. Temporary Closures of Locations.....                              | 30          |
| Section 5.07. Taxes.....  | 31          |
| Section 5.08. Minority-, Woman-, & Veteran-Business Participation.....          | 32          |
| Section 5.09. Updates to Exhibits C & D.....                                    | 32          |
| Section 5.10. Ancillary Wireless Services.....                                  | 33          |
| ARTICLE VI. REPRESENTATIONS & WARRANTIES OF THE CITY.....                       | 33          |
| Section 6.01. City Representations.....   | 33          |
| ARTICLE VII. REPRESENTATIONS & WARRANTIES OF THE COMPANY.....                   | 35          |
| Section 7.01. Company Representations.....                                      | 35          |
| ARTICLE VIII. INDEMNIFICATION.....  | 36          |
| Section 8.01. Indemnification by the City.....                                  | 36          |
| Section 8.02. Indemnification by the Company.....                               | 37          |
| Section 8.03. Indemnification Notice; Litigation Notice.....                    | 38          |
| Section 8.04. Defense of Third Party Claims.....                                | 38          |
| Section 8.05. Disagreement Notice.....  | 39          |
| Section 8.06. Payment of Indemnity Losses.....                                  | 39          |
| Section 8.07. Limitation of Damages.....  | 39          |
| ARTICLE IX. DISPUTE RESOLUTION.....   | 40          |
| Section 9.01. Scope.....  | 40          |

## TABLE OF CONTENTS

|   | <u>Page</u> |
|---|-------------|
| Section 9.02. Informal Dispute Resolution.....              | 40          |
| Section 9.03. Mediation.....                                | 40          |
| Section 9.04. Arbitration.....                              | 41          |
| ARTICLE X. COMPLIANCE WITH LAWS.....                        | 42          |
| Section 10.01. Compliance with Laws.....                    | 42          |
| Section 10.02. Non-Discrimination.....                      | 42          |
| Section 10.03. Federal Non-Discrimination Laws.....         | 43          |
| Section 10.04. Drug-Free Workplace Certification.....       | 43          |
| Section 10.05. Regulations on Public Vehicles for Hire..... | 43          |
| Section 10.06. Future Laws.....                             | 43          |
| ARTICLE XI. New financial structure.....                    | 44          |
| Section 11.01.....  | 44          |
| ARTICLE XII. MISCELLANEOUS.....                             | 44          |
| Section 12.01. Public Announcements.....                    | 44          |
| Section 12.02. Costs & Expenses.....                        | 44          |
| Section 12.03. Further Assurances.....                      | 44          |
| Section 12.04. Addresses for Notices, Etc.....              | 45          |
| Section 12.05. Third-Party Beneficiaries.....               | 45          |
| Section 12.06. Headings.....                                | 46          |
| Section 12.07. Construction.....                            | 46          |
| Section 12.08. References.....                              | 46          |
| Section 12.09. Severability.....                            | 46          |
| Section 12.10. Entire Agreement & Amendment.....            | 46          |
| Section 12.11. No Waiver; Cumulative Remedies.....          | 47          |
| Section 12.12. Successors & Assigns; Assignment.....        | 47          |
| Section 12.13. Confidentiality.....                         | 47          |
| Section 12.14. Independent Contractor.....                  | 47          |
| Section 12.15. Force Majeure.....                           | 47          |
| Section 12.16. Court Proceedings.....                       | 48          |
| Section 12.17. Non-Collusion.....                           | 49          |
| Section 12.18. Conflict of Interest.....                    | 49          |
| Section 12.19. Counterparts.....                            | 49          |

- EXHIBIT A. PHASE ONE LOCATIONS.
- EXHIBIT B. SUBSEQUENT PHASE LOCATIONS.
- EXHIBIT C. INSTALLATION REQUIREMENTS.
- EXHIBIT D. TECHNICAL DESCRIPTION OF ELEMENTS COMPRISING A LOCATION.
- EXHIBIT E. ESTIMATED BUDGET FOR IPL'S COSTS.
- EXHIBIT F. PARENT GUARANTY.
- EXHIBIT G. MAP OF IPL'S ASSIGNED SERVICE TERRITORY
- EXHIBIT H. ESCROW AGREEMENT
- EXHIBIT I. IPL'S WORK

## AMENDED AND RESTATED ELECTRIC VEHICLE SHARING CONCESSION AGREEMENT

THIS AMENDED AND RESTATED ELECTRIC VEHICLE SHARING CONCESSION AGREEMENT ("Agreement"), dated as of the 31st day of March, 2015 (the "Effective Date"), is made and entered into by and between the City of Indianapolis, Indiana, a municipal corporation, acting by and through the Office of the Mayor (hereinafter referred to as the "City") and BlueIndy, LLC, an Indiana limited liability company (hereinafter referred to as the "Company"). This Agreement amends and restates in its entirety the Electric Vehicle Sharing Concession Agreement dated April 8, 2014 as amended by a First Amendment dated October 1, 2014 and a Second Amendment dated February 27, 2015 (the "Original Agreement").

### WITNESSETH:

WHEREAS, Mayor Gregory A. Ballard has articulated a vision and strategy for Indianapolis to lead the way to achieve energy choices in the United States and, as a result of the Mayor's leadership, the Company identified Indianapolis as the ideal community in the United States to launch its Electric Vehicle (EV) sharing program;

WHEREAS, Bolloré S.A., through its French subsidiaries Autolib' in Paris, Bluely in Lyon and Bluecub in Bordeaux, has enjoyed great success with its EV sharing services, and the Company, an indirect subsidiary of Bolloré S.A., intends to implement its EV sharing by providing Charging Stations and Kiosks at approximately two hundred (200) sites in IPL's Assigned Service Territory, which will make Indianapolis one of the most electrified cities in the United States;

WHEREAS, as a result of the Company's interest, and following extensive discussions between the City and Indianapolis Power & Light Company (IPL), which is Marion County's authorized public utility provider of electricity, IPL is willing to assist the City with the project by providing electric utility line extensions for the Charging Stations and program Kiosks through a separate contract with the City (the "IPL Agreement");

WHEREAS, each Party and IPL is dedicating significant resources to this car-sharing program in the forms of substantial direct investment and in-kind investments so that the broader Marion County community will benefit from the new transportation option, the additional utility infrastructure, and an environment favorable to the greater adoption of EVs;

WHEREAS, numerous employers and individuals in Marion County, are supportive of this program and many have professed their intent to utilize the Services to be provided by the Company; and

WHEREAS, IPL accepted a modification to the Alternative Regulatory Plan and associated Settlement Agreement set forth in the IURC's February 11, 2015 Order which reduced IPL's obligations for installation work for the Charging Stations and program Kiosks totaling Sixteen Million Dollars (\$16,000,000) to install utility line extensions for approximately Three Million Seven Hundred Thousand Dollars (\$3,700,000). (the "Modified Order").

WHEREAS, as a result of the Modified Order, the City and Company desire to amend and restate the Original Agreement in its entirety to reflect the obligations of the Parties and IPL.

NOW, THEREFORE, in consideration of the foregoing and the mutual covenants and promises contained in this Agreement and other good and valuable consideration, the receipt and sufficiency of which are hereby acknowledged, the Parties, intending to be legally bound, hereby agree as follows:

AGREEMENT

ARTICLE I.  
DEFINITIONS

Section 1.01. Definitions. Capitalized terms used but not otherwise defined throughout this Agreement shall have the meanings indicated below:

- (a) "Affiliate" means, with respect to any Person, any other Person that directly or indirectly controls, is controlled by or is under common control with such Person.
- (b) "Agreement" has the meaning ascribed to such term in the introductory paragraph.
- (c) "Ancillary Services" has the meaning ascribed to such term in Section 6.01.
- (d) "Assigned Service Territory" has the meaning ascribed to such term in Section 6.01.
- (e) "Business" means the provision of the Services by the Company.
- (f) "CBD" has the meaning ascribed to such term in Section 5.03(d).
- (g) "Charging Stations" has the meaning ascribed to such term in Section 2.03.
- (h) "City" has the meaning ascribed to such term in the introductory paragraph.
- (i) "City Indemnified Parties" has the meaning ascribed to such term in Section 8.02.
- (j) "City Representative" has the meaning ascribed to such term in Section 2.02.
- (k) "City's Work" has the meaning ascribed to such term in Section 2.04.
- (l) "Claimant" has the meaning ascribed to such term in Section 8.03.
- (m) "Company" has the meaning ascribed to such term in the introductory paragraph.
- (n) "Company Indemnified Parties" has the meaning ascribed to such term in Section 8.01.
- (o) "Company Representative" has the meaning ascribed to such term in Section 2.02.
- (p) "Contract" means any contract, agreement, indenture, note, bond, loan,

instrument, lease, conditional sale contract, mortgage, license, franchise, insurance policy, commitment or other arrangement or agreement, whether written or oral.

(q) "Court Order" means any order, judgment, or decree of a court having jurisdiction.

(r) "Cure Period" has the meaning ascribed to such term in Section 2.03(a)(i)(C).

(s) "Customer Agreement" and "Customer Call Center" have the meaning ascribed to such terms in Section 2.03.

(t) "Deadline" has the meaning ascribed to such term in Section 2.03(a)(i)(C).

(u) "Delay Day" has the meaning ascribed to such term in Section 2.04.

(v) "Disagreement Notice" has the meaning ascribed to such term in Section 8.05.

(w) "Early Termination Payment" has the meaning ascribed to such term in Section 4.03.

(x) "Effective Date" has the meaning ascribed to such term in the introductory paragraph.

(y) "Election Notice" has the meaning ascribed to such term in Section 8.04.

(z) "Encumbrance" means all liens (statutory or other), leases, mortgages, pledges, security interests, conditional sales agreements, charges, claims, options, easements and other encumbrances of any kind or nature whatsoever.

(aa) "Escrow" means the escrow created pursuant to this Agreement as set forth in Exhibit H.

(bb) "Escrow Account" means an escrow account maintained with Escrow Agent, from which disbursements shall be made by Escrow Agent to the Company pursuant to this Agreement as set forth in Exhibit H.

(cc) "Escrow Agent" means an escrow agent mutually agreeable to the Parties to hold the Escrowed Funds.

(dd) "Escrowed Funds" means, at any given time, the funds on deposit in the Escrow Account.

(ee) "Exclusive Right" has the meaning ascribed to such term in Section 2.01.

(ff) "Exempt Taxes" has the meaning ascribed to such term in Section 5.07.

(gg) "Extension Services" shall be synonymous with the term "IPL's Work".

(hh) "Failure" has the meaning ascribed to such term in Section 2.03(a)(i)(C).

(ii) "Failure Notice" has the meaning ascribed to such term in Section 2.03(a)(i)(C).

(jj) "Fair Market Value" of the Location Fixtures with respect to the purchase thereof by the City pursuant to Section 4.04 shall be the Fair Market Value determined by the Parties after a reasonable period of negotiations. If the Parties cannot reach agreement on the Fair Market Value in thirty (30) days from the date of the City's exercise of the Option, the Company shall select a qualified business appraiser to determine the Fair Market Value; *provided however*, that, if the City so elects within thirty (30) days of the receipt of the original valuation by the appraiser selected by the Company, the City may also select a qualified business appraiser to conduct an appraisal. If the appraisals of the two (2) appraisers are within ten percent (10%) of each other, the price shall be based on the average of the two (2) appraisals; otherwise, the Parties shall select a third mutually acceptable qualified business appraiser and the price shall be based on the average of the two (2) closest appraisals or, if the highest and lowest appraisals, respectively, exceed and are less than the middle appraisal by the same amount, the price shall be based on the value set forth in the middle appraisal. Each appraiser shall base his, her or its appraisal of the Fair Market Value of the Location Fixtures based on the highest and best price that could be obtained in an orderly sale of assets by a willing seller from a willing buyer.

(kk) "Good Reason" has the meaning ascribed to such term in Section 2.05.

(ll) "Governmental Entity" means any court, government agency, department, commission, board, bureau or instrumentality of the United States, any local, county, state, federal or political subdivision thereof, or any foreign governmental entity of any kind.

(mm) "Guarantor," "Guaranty Conditions," and "Guaranty Obligations" have the meanings ascribed to such terms in Section 4.03.

(nn) "Indemnification Notice" and "Indemnifying Party" have the meanings ascribed to such terms in Section 8.03.

(oo) "Indemnity Loss" means readily quantifiable, non-speculative damages, losses, obligations, claims, Encumbrances, penalties, costs and expenses, including costs of investigation and defense and reasonable attorneys' fees and costs where expressly permitted by this Agreement, but excluding any incidental, consequential, punitive or exemplary damages, special damages, indirect damages, unrealized expectation, lost profits or other similar items, and under no circumstances shall any damages be calculated using a "multiplier" or any similar method having a similar effect.

(pp) An "Independent Accountant" shall be selected through the following process: in the event the Parties cannot mutually agree within thirty (30) days of the request for an audit under Section 5.02 on the selection of a reputable accounting firm to perform said audit, (i) the City shall first propose to the Company a reputable accounting firm to perform the requested audit, which the Company shall accept or reject; (ii) if the Company does not accept the City's proposed accounting firm within ten (10) days, the Company shall propose to the City a reputable accounting firm to perform the requested audit, which the City shall accept or reject; and (iii) if the City does not accept the Company's proposed accounting firm within ten (10) days, a reputable accounting firm shall be selected by mutual agreement of each accounting firm

proposed by each Party.

(qq) "Initial Term" has the meaning ascribed to such term in Section 4.01.

(rr) "Installation Requirements" means the description in Exhibit C of the work planned to install Location Fixtures and their connection to electrical and telecommunications network, including parts of the City's Work and IPL's Work.

(ss) "IPL Agreement" has the meanings ascribed to such term in the recitals.

(tt) "IPL's Alternative Regulation Plan" has the meaning ascribed to such term in Section 11.01.

(uu) "IPL's Costs" shall mean the total expenditure IPL will incur for labor, materials, overhead and supervision in the performance of IPL's Work. For the avoidance of doubt, the Parties acknowledge that IPL's Costs consist only of those standard and customary costs charged by IPL to its customers for services comparable to IPL's Work.

(vv) "IPL's Work" means that part of the City's Work to be performed by IPL as set forth on Exhibit I.

(ww) "IURC Approval" has the meaning ascribed to such term in Section 11.01.

(xx) "Kiosk" means a typical kiosk facility placed at the various Locations and provided and used by the Company for its exclusive use to service its customers.

(yy) "Law" means any local, county, state, federal, foreign or other law, statute, regulation, ordinance, rule, order, decree, judgment, consent decree, settlement agreement, export control restriction or governmental requirement enacted, promulgated, entered into, agreed or imposed by any Governmental Entity.

(zz) "Liability" with respect to any Person, means any liability or obligation of such Person of any kind, character or description, whether known or unknown, absolute or contingent, accrued or unaccrued, disputed or undisputed, liquidated or unliquidated, secured or unsecured, joint or several, due or to become due, vested or unvested, executory, determined, determinable or otherwise, and whether or not the same is required to be accrued on the financial statements of such Person.

(aaa) "Liquidated Damages" has the meaning ascribed to such term in Section 2.03(a)(i)(C).

(bbb) "Litigation Notice" has the meaning ascribed to such term in Section 8.03.

(ccc) "Locations" means any and all space in Marion County, Indiana of which the Company is granted exclusive use and common use under this Agreement and any other Location as may be agreed to between the Parties; *provided however*, that the Parties understand and agree that with respect to IPL's Work, in no event shall a Location be located outside of IPL's Assigned Service Territory.



(ddd) "Location Fixtures" means the Kiosks, Charging Stations, cabling and any other permanent structures at the Locations owned by the Company.

(eee) "Mediator" has the meaning ascribed to such term in Section 9.03.

(fff) "Meter Location" shall have the meaning ascribed to such term in Section 6.01(e).

(ggg) "Net Profit" shall mean for each calendar year, revenues generated by the Services (including advertising but excluding Ancillary Services), minus all operating costs and investment amortization and depreciation for the Services (including advertising but excluding Ancillary Services), as determined in accordance with GAAP. For the avoidance of doubt, Ancillary Services shall not be included in the calculation of Net Profit.

(hhh) "Notice to Proceed" has the meaning ascribed to such term in Section 2.04.

(iii) "Option," "Option Notice," and "Option Period" have the meanings ascribed to such terms in Section 4.04.

(jjj) "Original Installation Date" means the date the Company receives notice from IPL that the Location Fixtures at a Location are ready to be tested and commissioned.

(kkk) "Parking Taxes" means Taxes imposed by the City or Marion County, Indiana, on the Company or its customers using the Services imposed solely on the privilege of parking a Vehicle at a Location. Parking Taxes do not include fees, penalties, or other costs associated with parking tickets for unauthorized parking of Vehicles.

(lll) "Party" or "Parties". The City and the Company are each sometimes referred to herein, individually, as a "Party" and, collectively, as the "Parties."

(mmm) "Perimeter" has the meaning ascribed to such term in Section 2.04.

(nnn) "Permitted Reimbursement Costs" means costs that are eligible to be paid (or reimbursed to the Company) as set forth in Exhibit H.

(ooo) "Person" means any individual, corporation, partnership, joint venture, association, limited liability company, joint-stock company, trust or unincorporated organization, or any Governmental Entity, officer, department, commission, board, bureau or instrumentality thereof.

(ppp) "Personnel" means any director, officer, or employee of the Company or the City, as applicable.

(qqq) "Phase One" has the meaning ascribed to such term in Section 2.04.

(rrr) "Phase One Locations" has the meaning ascribed to such term in Section 2.04.

(sss) "Proceeding" means any action, arbitration, audit, hearing, investigation,

litigation or suit.

(tt) "Profit Share" has the meaning ascribed to it in Section 5.02.

(uuu) "Profitability" shall mean the point in time when the Company's cumulative Net Profit from the Effective Date is positive.

(vvv) "Project" has the meaning ascribed to such term in the Project Agreement.

(www) "Public Opening" has the meaning ascribed to such term in Section 2.03.

(xxx) "Renewal Term" has the meaning ascribed to such term in Section 4.01.

(yyy) "Services" has the meaning ascribed to such term in Section 2.03.

(zzz) "Subsequent Phase" and "Subsequent Phase Locations" have the meanings ascribed to such terms in Section 2.04.

(aaaa) "Tax" means any income, gross receipts, license, payroll, employment, excise, severance, stamp, occupation, premium, windfall profits, environmental, customs duties, permit fees, capital stock, franchise, profits, withholding, social security, unemployment, disability, real property, personal property, parking, sales, use, transfer, registration, value added, alternative or add-on minimum, estimated or other tax, levy, impost, stamp tax, duty, fee, withholding or similar imposition of any kind payable, levied, collected, withheld or assessed at any time, including any interest, penalty or addition thereto, whether disputed or not.

(bbbb) "Temporary Closure" means any interruption to or any suspension of the Services by the City due to inaccessibility or non-usability of a Location by the Company for any reason including parking bans, weather-related street closures, sidewalk closures related to building construction, sidewalk construction or repair, street construction or repair, utility work, and similar activities.

(cccc) "Temporary Closure Amount" shall be the product of (i) the ratio of (A) the number of affected Charging Stations to (B) the total number of Charging Stations in service on the first day of the Temporary Closure multiplied by (ii) the Revenue received from all Locations during the period equal to the duration of the Temporary Closure immediately prior to the Temporary Closure.

(dddd) "Term" has the meaning ascribed to such term in Section 4.01.

(eeee) "Vehicles" means the Company's fleet of electric motor vehicles designed primarily for the carriage of passengers that the Company owns, leases, rents, or intends to rent and are properly available or will become available for rental as provided herein.

**ARTICLE II.**  
**EXCLUSIVE RIGHT; INFRASTRUCTURE IMPROVEMENTS**

**Section 2.01.**    **Exclusive Right.**

(a)    The City hereby grants to the Company the exclusive right to provide a car-sharing service on city-owned property and city-controlled public rights of way (the "Exclusive Right").

(b)    By virtue of the Exclusive Right, the Company shall be permitted to use (and to allow its customers to use) the Locations for the purpose of:

- (i)    Parking Vehicles;
- (ii)   Offering the use of Charging Stations to private owners of EVs;
- (iii)   Establishing and operating Kiosks, Charging Stations and such other associated technology and items as may be necessary or appropriate for the proper operation of the Business;
- (iv)   Advertising and marketing, as provided in Article V; and
- (v)    Doing such other acts and things as are reasonably related to the Business.

(c)    The City agrees that, during the Term, the City shall not grant any lease, license, easement or other right similar to the Exclusive Right to any other Person, nor enter into any Contract with any Person for any purpose similar to the purpose of this Agreement anywhere else within Marion County, Indiana.

(d)    For the avoidance of doubt, the Parties agree that the following are not subject to the prohibitions contained in subsection (c); *provided however*, that none of the following shall enable the deployment of a competing car-sharing service as prohibited in Section 2.01(c):

- (i)    The ownership and use of EVs in Marion County, Indiana;
- (ii)   The installation, operation, or maintenance of any EV charging infrastructure by the City or other Persons;
- (iii)   The provision and regulation of car rental, limousine, taxi, and ride sharing services offered by other Persons provided that such services are not offered in conjunction with the City;
- (iv)   Bike sharing services offered by other Persons, including such services offered in conjunction with the City;
- (v)    Bus, light rail, and other mass transit options offered by any Governmental Entity; and,
- (vi)   The installation, maintenance, and ongoing use of IPL's EV charging

infrastructure or any other activity whatsoever by IPL; provided that such use or activity does not involve supporting a competing EV car-sharing service other than by offering retail electric service pursuant to IPL's tariffs approved by the IURC. The provision of retail electric service, in accordance with IURC rules and Indiana statutes, will be provided to any other such party on a nonexclusive basis. The City agrees that the IPL Agreement will include a provision containing the same obligation for IPL as set forth in this Section 2.01(d)(vi).

(e) Except as otherwise provided in this Agreement, any use of the Locations by any Person other than the Company, its subcontractors, or its customers shall be prohibited, and the Company shall be authorized to take any actions permitted by Law to enforce this requirement.

(f) The Company shall at all times occupy and use only the space within the confines of the Locations. In the event that the Company exceeds such confines on the public rights of way, the City shall notify the Company in writing of any such condition and the Company shall, upon receipt of written notice, vacate said area immediately.

Section 2.02. Designation of Representatives.

(a) The City shall designate one (1) individual to serve as the single point of contact for purposes of communications between the City and the Company regarding the subject matter of this Agreement (the "City Representative").

(b) The City Representative shall be authorized and empowered to give and receive all notices, demands and other communications, including agreeing to Locations as provided in Section 2.05, and to take actions (including the granting of waivers), for and on behalf of the City as permitted by Law; *provided however*, the City Representative cannot waive the requirements of Section 2.03(a)(i). The City Representative shall help coordinate with the State of Indiana, IPL and other utilities, and any other entity in Marion County, Indiana, to the maximum extent possible to assist the Company in its operation of the Business.

(c) The Company shall designate one (1) individual to serve as the single point of contact for purposes of communications between the City and the Company regarding the subject matter of this Agreement (the "Company Representative"). The Company Representative shall be authorized and empowered to give and receive all notices, demands and other communications. The Company Representative shall be located in Indianapolis at the time of the Public Opening and thereafter during the Term.

(d) A Party may designate a replacement representative from time to time by delivering written notice thereof. (Notwithstanding Section 12.04, notice for this designation may be provided by electronic mail to the other Party.)

Section 2.03. Services by the Company. During the Term, the Company agrees to provide the following Services:

(a) Rentals of the Vehicles & Charging Stations.

- (i) The Company shall provide, manage, operate, and maintain rental agreements for Vehicles in a quantity anticipated to be five hundred (500) and shall provide, manage, operate, and maintain Charging Stations in a quantity anticipated to be one thousand (1,000) at approximately two hundred (200) Locations by the time of full implementation of the Services, but the total number of Vehicles and Charging Stations deployed for use by customers of the Services shall be set at the sole discretion of the Company; *provided however*, the following minimum requirements, notwithstanding any other provision in this Agreement, shall be performed by the Company during the Term:
- (A) There shall be twenty-five (25) Locations deployed for use by customers at the time of the Public Opening;
  - (B) There shall be at least 0.4 Vehicles deployed for each Charging Station deployed;
  - (C) There shall be no fewer than one hundred and twenty five (125) Vehicles, fifty (50) Locations, and two hundred and fifty (250) Charging Stations deployed by December 31, 2016 for use by customers during the Term.

The Company represents that it fully intends to deploy five hundred (500) Vehicles and one thousand (1,000) Charging Stations at approximately two hundred (200) Locations by the time of full implementation of the Services; however, the Parties recognize that market factors may dictate that fewer Vehicles, Charging Stations, and/or Locations are necessary to meet customer demand in Marion County.

In the event there are less than two hundred and fifty (250) Vehicles, one hundred (100) Locations, and five hundred (500) Charging Stations deployed for use by customers on June 30, 2017, the Company shall provide sufficient information to the City to demonstrate why the market could not sustain deployments at this level and the Parties shall confer in good faith to investigate ways to increase customer demand.

If Public Opening does not occur by December 31, 2015, or if at least fifty (50) Locations are not available to the public by December 31, 2015, in each case, for any reason (either or both, a "Failure" and the dates, the "Deadline") and IPL gives the Company written notice that a Failure has occurred (the "Failure Notice"), the Company agrees to pay IPL One Million Dollars (\$1,000,000) (the "Liquidated Damages") at the end of the Cure Period if the Failure is not cured. The Company shall have a period of three months (the "Cure Period") after the Deadline to cure the Failure.

If the IPL Agreement is terminated because the IURC ARP Order has been appealed, the Company's failure to meet the conditions in the first sentence of this paragraph shall not be a Failure. If the Company is delayed at any time in installation of one or more Locations by an act or neglect of IPL, then the Deadline shall be extended for such reasonable time as IPL shall determine; provided, however, that a claim for extension of the Deadline must be initiated by written notice from the Company to IPL within twenty-one (21) days after occurrence of the event giving rise to such claim or within twenty-one (21) days after the Company first recognizes the condition giving rise to the claim, whichever is later. The Company intends that the Liquidated Damages constitute compensation, and not a penalty. The Company acknowledges and agrees that IPL's harm caused by a Failure would be impossible or very difficult to accurately estimate at this time, and that the Liquidated Damages are a reasonable estimate of the anticipated or actual harm that might arise from a Failure. The Company's payment of the Liquidated Damages is IPL's exclusive remedy for a Failure. The occurrence of a Failure shall not give the City the right to terminate this Agreement pursuant to Section 4.02(c). For the avoidance of doubt, in addition to the Liquidated Damages due at the end of the Cure Period if the Failure is not cured, IPL will be entitled to payment of IPL's Costs incurred as of the termination date pursuant to Section 4.03(a) if this Agreement is terminated by the City pursuant to Section 4.02(c). This paragraph may not be modified in any way without the express written consent of IPL. This paragraph will survive the termination of this Agreement.

- (ii) The terms and conditions of a rental of a Vehicle or use of a Charging Station by a customer shall be set by the Company and will be set forth in a contract between the Company and each customer (the "Customer Agreement"). The Customer Agreement shall disclose that each of the Vehicles includes a monitoring system that will:
  - (A) Enable customers to contact the Customer Call Center;
  - (B) Provide GPS guidance to the customer;
  - (C) Track the Vehicles; and
  - (D) Transmit to the Customer Call Center information about the Vehicle, including battery power level and other vehicle statistics.

Except as required by Law or by this Agreement, the Company shall, in its sole discretion, determine the terms of the Customer Agreement.

- (iii) The Vehicles will be authorized to be driven in a limited perimeter as set forth in the Customer Agreement and as may be changed from time to time by the Company; *provided however*, this limited perimeter shall, at minimum, include all of Marion County and any portion of another county within three (3) miles of the Marion County limit.

(iv) The Parties acknowledge that use of the Services by owners of privately owned EVs is an important factor in the success of the Services. Use of the Services shall be encouraged by the Company so long as such use does not unreasonably inhibit the use of the EV sharing Services and such use complies with the terms of the Customer Agreement.

(b) Supply, Operation, & Maintenance of Kiosks. The Company shall provide, manage, operate, and maintain in good, working condition all of the Kiosks at the Locations. Unless otherwise agreed by the Parties and except as may be reasonably prevented by technical or legal reasons, over the course of the Term, not less than ten percent (10%) of the Locations will include a sheltered Kiosk to allow customers to manage their subscription to the Services.

(c) Customer Call Center. The Company will implement and maintain a 24-hour customer call center (the "Customer Call Center") in order to assist potential customers in subscribing to use the Services and to assist customers with any problems in using the Services. The Customer Call Center will be fully operational and serving customers by the Public Opening and thereafter during the Term.

(d) Maintenance & Support Services. The Company will use commercially reasonable efforts to provide maintenance and support for the Vehicles and the Kiosks to ensure the Services are provided on a non-interrupted and consistent manner.

(e) Movement of Vehicles. The Company shall use reasonable efforts to move the Vehicles between Locations as necessary to help ensure availability of the Services to customers.

Section 2.04. Implementation.

(a) To help ensure the smooth and successful implementation of the Services, the introduction of the Business into Marion County, Indiana will be sequenced in phases, as follows:

(i) Demonstration & Testing.

(A) The City and the Company have selected the north side of Washington Street just east of Meridian Street as a Location to demonstrate the Services in Indianapolis, where the Company shall provide free demonstrations. If the demonstration site has not been installed by Company, then, upon full execution of this Agreement and the IPL Agreement, the City will authorize IPL to commence IPL's Work at this demonstration Location.

(B) After the demonstration and prior to the Public Opening, the Company shall test the various components of its Services.

(C) Nothing provided in this Section 2.04(a)(i) shall be cause for termination by either Party pursuant to Section 4.02(c), as the Parties intend the obligations hereunder to be performed utilizing their reasonable best efforts so as to raise public awareness about

the Services and to help ensure smooth launch of the Services at the Public Opening.

- (ii) Company Acceptance of Typical Site Drawing. Prior to the implementation of Phase One, the City will provide, and the Company will accept in writing, an agreed scaled typical site drawing provided by the City, stamped by an Engineer of Record who is a Professional Engineer licensed in the State of Indiana, depicting the typical placement of Location Fixtures that comply with existing setbacks and easements and all applicable Laws, such as but not limited to, local zoning requirements; historic district requirements; and the Americans with Disabilities Act.
  
- (iii) Phase One. The first phase of the introduction of the Business ("Phase One") shall consist of deployment of the Services at or near the Locations listed in Exhibit A ("the Phase One Locations") except as the Parties mutually agree otherwise to improve the launch of the Services. The City's acceptance of a proposed change to any Phase One Location shall not be unreasonably withheld.
  - (A) Before the City's Work begins in Phase One, the City shall accept or reject a Notice to Proceed within fourteen (14) days of receipt thereof. Failure to accept or reject a Notice to Proceed by the end of such fourteen (14) day period will be deemed an acceptance.
  - (B) The City's Work during Phase One shall begin upon the City's acceptance of Notice to Proceed, and the City shall complete its work within the time period set forth in the Notice to Proceed (which date shall have been proposed as a result of collaboration between the City and the Company).
  - (C) During Phase One and for a period of up to forty-five (45) days after the completion of the City's Work during Phase One, the Company shall determine whether the Location Fixtures are installed properly. In the event any Location Fixture at a Phase One Location is deemed by the Company to not be installed in accordance with the Installation Requirements, the City and the Company shall meet as necessary and take such actions in accordance with each of their respective responsibilities under this Agreement to resolve the issues promptly. The Company shall provide written acceptance or rejection of the City's Work in Phase One within forty-five (45) days of its completion. Failure to accept or reject the City's Work in Phase One by the end of such forty-five (45) day period will be deemed an acceptance.
  - (D) Within sixty (60) days of the Company's acceptance of the City's Work in Phase One, the Company shall complete its deployment of Vehicles for the Locations in Phase One. When the Company has completed all necessary testing and makes a determination that the Services are operating properly, the Company will consult with the



City to schedule an official opening of the Services to the public (the "Public Opening"). The Company shall notify the City Representative of the date selected at least thirty (30) days in advance of any public notice of the Public Opening.

- (E) Subject to similar efforts from IPL, the Company and the City agree to use commercially reasonable efforts to complete Phase One as expeditiously as possible.
- (iv) Subsequent Phases: The following shall occur during phases after Phase One ("Subsequent Phases"):
- (A) At such time after Phase One when the Company issues a Notice to Proceed during a Subsequent Phase, the City shall accept or reject a Notice to Proceed within fourteen (14) days of receipt thereof. Failure to accept or reject a Notice to Proceed by the end of such fourteen (14) day period will be deemed an acceptance.
  - (B) The City's Work during a Subsequent Phase shall begin upon the City's acceptance of Notice to Proceed, and the City shall complete its work within sixty (60) days of the City's acceptance of a Notice to Proceed unless a different period of time is set forth in the Notice to Proceed or as provided under Section 2.04(a)(v).
  - (C) The Company shall provide written acceptance or rejection of the City's Work at a Location within thirty (30) days of its completion. Failure to accept or reject the City's Work at a Location by the end of such thirty (30) day period will be deemed an acceptance.
  - (D) Within forty-five (45) days of completion of the City's Work in a Subsequent Phase, the Company shall complete its deployment of Vehicles for the Locations in that Subsequent Phase and shall have the Charging Stations and Kiosks fully operational for customer use.
- (v) Special Circumstances. If, in the City's reasonable judgment, there are unique and special circumstances relating to a specific Location that would prevent the City from completing the City's Work within the time required by a Notice to Proceed, the Parties will discuss until the City selects the earliest practical date for completion of the City's Work at the affected Location. The availability of a subcontractor shall not be reason for the City to request additional time under this Section 2.04(a)(v) and the City's Work on other unaffected Locations in the Notice to Proceed shall not be delayed by reason of this Section 2.04(a)(v).
- (vi) Weekly Calls. The Company shall conduct status calls with IPL on a weekly basis for the first six (6) months of performance of the Extension Services and at least monthly thereafter unless otherwise agreed upon in writing by the Parties

(b) Notice to Proceed.

- (i) A Notice to Proceed is a written notice issued by the Company that, when either accepted in writing by the City or not rejected in writing within fourteen (14) days of issuance of the Notice to Proceed, requires the City to begin the City's Work in Phase One or a Subsequent Phase.
- (ii) Each Notice to Proceed will include:
  - (A) A list of Locations proposed for that phase; *provided however*, that no Notice to Proceed in a Subsequent Phase shall include more than four (4) Locations;
  - (B) The number of Charging Stations that will be located at each Location and whether each such Location will contain an enrollment Kiosk;
  - (C) An aerial drawing (to scale) showing the specific locations for each Location Fixture to be installed;
  - (D) Details with respect to the City's Work, if any;
  - (E) Details with respect to any work to be performed by the Company or any other entity, if any;
  - (F) If longer than sixty (60) days, a timeline for completion of the City's Work;
  - (G) A perimeter around the parking spaces at each Location where all Locations Fixtures and the Meter Pedestal will be installed and extends no more than ten (10) feet beyond the parking locations in either direction (the "Perimeter"); and
  - (H) Confirmation from IPL that it has the necessary easement or easements to extend the electrical service to the proposed Location. (The City acknowledges that the IPL Agreement shall include the requirement that IPL identify any utility easements IPL currently holds on or in the vicinity of proposed Locations within five (5) business days of such request from the Company).
- (iii) Each Notice to Proceed that includes a Location that is not situated entirely on city-owned property or city-controlled public right of way shall also include:
  - (A) A representation that the Company has secured all rights necessary for the City, IPL, and their respective Personnel, subcontractors, agents, and Affiliates to access the proposed Location and to perform the City's Work at that proposed Location if accepted; and,

- (B) The contact information, including telephone number and email address, for an authorized individual for the property on which the Location Fixtures will be located.
- (iv) Notwithstanding any other provision of this Agreement, the City shall accept the Notice to Proceed unless:
  - (A) The City has "Good Reason" to reject a Location in the list included with the Notice to Proceed, which may only be altered or rejected as provided under Section 2.05; or,
  - (B) The terms of the Notice to Proceed conflict with the requirements of this Agreement.
- (v) The Company shall not issue more than one (1) Notice to Proceed within a seven (7) day period unless the timeline for completion is staggered accordingly to comply with the other requirements of this Section 2.04(b).

(c) City Obligations. During the implementation, the City agrees to perform and complete, at its own cost and expense, or cause its subcontractors to perform and complete, the following work required for preparation of the Phase One Locations and Subsequent Phase Locations, as applicable, for use by the Company in the Business (the "City's Work"):

- (i) For Locations on city-owned property or city-controlled public right of way:
  - (A) Repairing all roads and sidewalks at or near the Locations;
  - (B) Providing all necessary signage and pavement marking in compliance with the Law and city signage policies and standards and as otherwise set forth in the Installation Requirements;
  - (C) Prohibiting parking by vehicles other than the Vehicles or vehicles whose customers have subscribed to the Services to charge a privately owned EV on the Charging Stations (including appropriate signage prohibiting such parking);
- (ii) Preparing drawings identifying the proposed location of each Location Fixture depicting the specific placement of Location Fixtures in compliance with existing setbacks and easements and all applicable laws, such as but not limited to, local zoning requirements; historic district requirements; and the Americans with Disabilities Act;
- (iii) Participating in on-site surveys of each proposed Location;
- (iv) Installing the power conduits listed in the Installation Requirements for each Location subject to 2.04(d)(i);
- (v) Cause IPL to install the electric service for each Location in accordance with Exhibit I subject to 2.04(d)(i);

- (vi) Expediting and obtaining all permits from the City necessary for the work performed by the Parties to the extent permitted by Law; and
- (vii) Participating in Location assessments after a Notice to Proceed is issued.

The City's Work shall conform to the Installation Requirements and be in accordance with each Notice to Proceed not rejected by the City as permitted by this Agreement.

(d) IPL's Costs.

- (i) The City represents that, based on the information provided by the Company and IPL, it has concluded that a budget of Three Million Seven Hundred Thousand Dollars (\$3,700,000) is sufficient to perform IPL's Work at one hundred ninety (190) Locations. Upon written request by the Company, the City shall provide to the Company, as may be reasonably necessary, a copy of work papers to support this budget. A copy of the revised estimated budget for IPL's Work is attached hereto as Exhibit E.
- (ii) The City shall provide, or cause IPL to provide, a monthly budget tracking report showing the number of Locations at which IPL's Work has been completed and the IPL Costs incurred to date.
- (iii) The Parties acknowledge and agree that, notwithstanding anything else in this Agreement, IPL's Costs shall not exceed Three Million Seven Hundred Thousand Dollars (\$3,700,000) therefore, the City shall not be required to have any additional performance by IPL of IPL's Work and the City shall not be required to perform work within the scope of IPL's Work in excess of that amount.
- (iv) The Parties further acknowledge and agree that IPL will not be required to perform IPL's Work past December 31, 2016 unless the Parties and IPL agree otherwise in writing. Other than as set forth in the prior sentence, there shall be no expectation nor any requirement for IPL's Work to continue thereafter unless it was begun at least sixty (60) days prior to December 31, 2016.
- (v) During the period that IPL's Work is being performed, the Parties shall meet and confer in good faith to consider options on how they can make the most cost-effective use of the Three Million Seven Hundred Thousand Dollars (\$3,700,000) budget for IPL's Work; *provided however*, such discussions shall not have any impact on the obligations of IPL except as may otherwise be agreed in writing by IPL.
- (vi) If IPL's Costs have reached Three Million Seven Hundred Thousand Dollars (\$3,700,000) and the Parties desire to further expand the Services, the Parties shall meet and confer in good faith to consider options for such expansion and shall invite IPL to join in such conversations; *provided however*, such discussions shall not have any impact on the obligations of

IPL except as may otherwise be agreed by IPL in writing. In case the \$3,700,000 are reached and the Company wishes IPL to perform Extension Services for additional locations, IPL shall charge the Company standard IPL tariff costs.

(e) Communications Connectivity to the Locations. The Company shall be responsible for the installation of the communications connectivity to the Locations in accordance to the Installation Requirements. The communications providers or any subcontractors thereof shall bill the Company for the costs of their services and the Company shall be responsible for paying those costs. The City shall coordinate such installation at each Location to ensure that installation of communications and electricity is performed at or near the same time in order to avoid any additional digging/filling of pavement and roads. The City shall make its best efforts to have the installation of the communications lines installed in the same trench as the electricity lines beginning at the point where the communications lines follow the same path as the electricity lines and to the applicable Location Fixture.

(f) Mutual Delays. If either Party delays the implementation schedule for reasons other than Force Majeure and causes the other party to be idle or otherwise incur staff or other costs waiting for the other Party to perform their part of the implementation of the Services, then such Party will owe the other Party the sum of \$1,200 per day of delay after the second day ("Delay Day"). The number of such Delay Days owed each Party will be tallied on a monthly basis and if the difference between the number of Delay Days owed to and due by a Party is greater than five (5) for that month, then the Party shall pay the corresponding sum within thirty (30) days. The cumulative amount of Delay Days for each Party will be reset to zero (0) on the first day of each month.

Section 2.05. Locations.

(a) The City and the Company agree that geographic placement of the Locations is a critical element to the success of the Company and the Locations are typically located outdoors and include on-street parking spaces for the Vehicles in order to provide the greatest visibility for customers.

(b) A technical description of the elements that comprise a Location is set forth in Exhibit D.

(c) The City shall make available up to one thousand (1,000) parking spaces within up to two hundred (200) sites within Indianapolis, Indiana to be used as Locations for the Service at no charge to the Company.

(i) To the extent the Company proposes a Location on property owned or controlled by another Governmental Entity (including the Indianapolis Airport Authority and the excluded cities of Beech Grove, Lawrence, Southport, and Speedway) or any other Person located in Marion County, Indiana, the City will assist the Company to help secure approval for the proposed Location from that Governmental Entity or Person; *provided however*, the Company acknowledges that the City does not warrant or

represent that it can secure approval from any other Governmental Entity or Person.

- (ii) The City shall not be required to pay any costs associated with securing rights to a Location that is not located on city owned property or city controlled public right of way.

(d) Unless a proposed Location is listed on Exhibit A or Exhibit B, the Company shall consult with the City to discuss the selection of new Locations prior to issuing a Notice to Proceed. The Parties understand that the City will, prior to the City's acceptance of a Notice to Proceed, consult with IPL on the Locations that are not listed on Exhibit A or Exhibit B that are proposed by the Company. The Parties shall take into consideration the proximity of electrical and communications connectivity points to avoid unnecessarily high installation costs.

(e) The City may only reject a Location on the list of Locations included with a Notice to Proceed for Good Reason. Such rejection shall be provided to the Company within fourteen (14) days of the City's receipt of the Notice to Proceed along with a written explanation explaining the Good Reason; *provided however*, that the City may reject a Location after acceptance if unforeseen conditions render the site impracticable for the installation of Location Fixtures. For purposes of this Section 2.05, the City shall have "Good Reason" for an objection to a proposed Notice to Proceed if and only if the selection or use of the Location would:

- (i) Result in a threat to the public's safety; or
- (ii) Result in impeding the City's ability to use the proposed location to address drainage/stormwater issues, promote economic development, mass transit, or to address other infrastructure needs; *provided however*, that this subpart (ii) shall not apply to Locations listed in Exhibit A or Exhibit B; or
- (iii) Result in the breach of, or constitute a material default under, any provision of Law applicable to the City or any Contract to which the City is a party; or
- (iv) Negatively impact in a material manner, as determined by IPL in its reasonable judgment with a written explanation provided to the City and the Company, the electric facilities owned and operated by IPL; or
- (v) Cause IPL's Costs for IPL's Work at a Location to be more than \$29,000 (representing the blended average of double the extension costs of the CBD and non-CDB Locations as shown on Exhibit E), unless agreed in writing between the Company, the City, and IPL; otherwise, the Company and the City shall collaborate with IPL to identify an alternative Location;
- (vi) Result in the City incurring an unacceptable amount, as determined by the City in its reasonable discretion, of costs associated with the removal of parking meters; *provided however*, that this subpart (vi) shall not apply to Locations at the addresses listed in Exhibit A or Exhibit B; or

- (vii) Have no place within the Perimeter where it is physically practical, in IPL's judgment, to locate a meter for reasons other than cost.

If, pursuant to Section 2.05(e)(i) through (v), the City objects to a Location for Good Reason, the City shall, *whenever possible*, offer alternative Locations within a reasonable distance from the proposed Location not to exceed approximately a quarter mile (measured by walking distance) and as close as is reasonably possible to existing communications and electrical connectivity points.

If, pursuant to Section 2.05(e)(v), the City objects to a Location for Good Reason, the City shall offer alternative Locations within a reasonable distance from the proposed Location not to exceed approximately a quarter mile (measured by walking distance) and as close as is reasonably possible to existing communications and electrical connectivity points.

If the City and the Company are unable to determine a mutually agreeable replacement Location or the Company objects to the City's "Good Reason," then they shall submit the dispute to the Dispute Resolution provisions in Article IX.

Notwithstanding Section 12.04, any Notice to Proceed or Good Reason provided under this Section 2.05 may be provided by electronic mail by the Company Representative to the City Representative or vice versa (as applicable).

(f) Except as provided in Section 2.05(e), no Party may change a Location in a Notice to Proceed that has been accepted without the written approval of the other Party.

(g) In the event a Party wishes to relocate a Location that already contains a Location Fixture, the Party desirous of the relocation shall reimburse:

- (i) The other Party for its actual reasonable costs incurred to relocate the Location Fixtures to the new Location, including any costs associated with any necessary modifications to the Location Fixtures; and
- (ii) IPL for the actual reasonable costs associated with the relocation so that IPL does not pay for the same Location more than once;

provided however, that no such reimbursement will be necessary if the Company demonstrates to the City and IPL that relocation of the Location will result in a more cost effective use of the Location Fixtures and improvement to the Profit Share.

**Section 2.06. Towing.**

(a) The Company and the City shall cooperate to establish, maintain, and undertake the enforcement of the policies and procedures established by the City and the Company for the administration and enforcement of parking rules and regulations in the Locations by such means as permitted by Law.

(b) The City, or its subcontractor, shall tow vehicles parked at a Location without authorization within one (1) hour after such vehicles are discovered by the City or after receiving

notification by the Company of such occurrence. The Company shall not be charged a fee or penalty associated with such a tow, as such shall be borne by the owner of the unauthorized vehicle and payable to the City as required by Law.

(c) The Company shall either have sufficient emergency services and equipment available or have sufficient third party contracts in place so that it can retrieve immobile Vehicles or Vehicles that are not returned properly to a Location by a Person. If the City, or its subcontractor, is required to tow a Vehicle for any reason, the Company shall not be charged more than any other party as required by Law, which the Parties acknowledge may change from time to time.

Section 2.07. Vehicle Type. The Company shall use the North American version of its Bluecar during Phase One and Subsequent Phases so long as such Bluecar is approved for use in the United States by the U.S. Department of Transportation and otherwise complies with all Laws. The Company shall promptly provide the City with the same information it provides to the U.S. Department of Transportation upon written request by the City. Should the average number of uses per Vehicle not exceed one in the last quarter of the second year after the Public Opening, the Parties shall meet in good faith to discuss changing the type of Vehicle, as well as any other facet of the Services, at the Company's expense.

### **ARTICLE III. MAINTENANCE & REPAIR**

#### Section 3.01. The City's Repairs.

(a) The City shall keep the foundations, streets, sidewalks, all structural parts of the Locations and any other element of the obligations of the City, including the City's Work, under this Agreement in reasonably good repair as it does throughout Marion County, Indiana.

(b) If the safe or proper functioning of the Services at the Locations (including any Location Fixtures) is unreasonably impaired by the state of the foundations, streets, sidewalks, structural parts of the Locations, or any other element of the obligations of the City under this Agreement, including the City's Work, the City shall make all necessary repairs to return to a state of safety and proper functioning within forty-five (45) days of the condition becoming known; *provided however*, that the City shall not be required to pay for any such repairs that become necessary by reason of the negligence of, recklessness of, or willful misconduct by the Company or its customers.

(c) Nothing in this Section 3.01 shall be construed to make the City responsible for maintaining or repairing the distribution or service lines located between the electric meter at the Locations and IPL's distribution system, as IPL is responsible for such maintenance and repairs.

#### Section 3.02. The Company's Replacement & Maintenance; Access to Locations.

(a) All repairs, replacements or maintenance to the Location Fixtures shall be made or performed, as applicable, by the Company or its subcontractors and the same shall at all times be kept in good order, condition, and repair by the Company (ordinary wear and tear and temporary outages and technical interruptions excepted) and shall comply with all Laws.



(b) The Company may from time to time and at any time replace or upgrade or make alterations or improvements to any of the Location Fixtures; *provided* that to the extent that such replacements, upgrades or alterations involves altering a public sidewalk or rights of way (such as drilling), the Company shall notify the City of any such replacements, upgrades or alterations within two (2) days before making the same and shall ensure that such alterations comply with the Law and the City's design standards.

Section 3.03. Encumbrances. The Company and the City shall keep the Locations and the Location Fixtures free from any Encumbrances.

#### ARTICLE IV. TERM, TERMINATION, & GUARANTY

Section 4.01. Term.

(a) The initial term of this Agreement shall commence on the Effective Date and shall terminate on the fifteen (15) year anniversary of the Public Opening (the "Initial Term").

(b) The Initial Term shall automatically renew for successive periods of two (2) years (each, a "Renewal Term," collectively with the Initial Term, the "Term") unless either the City or the Company provides written notice to the other of its intention not to renew at least ninety (90) days prior to the expiration of the current Term.

Section 4.02. Rights of Termination. Notwithstanding anything contained in this Agreement to the contrary, this Agreement may be terminated at any time, as follows:

- (a) By mutual written agreement of the City and the Company;
- (b) By the Company for convenience at any time after the five (5) year anniversary of the Effective Date by providing the City one-hundred and eighty (180) days prior written notice;
- (c) By the City, if there has been a material default or breach by the Company of any of the representations, warranties, covenants or agreements of the Company contained in this Agreement and such default or breach shall not have been waived by the City or cured by the Company within one-hundred and eighty (180) days after receipt by the Company of written notice from the City specifying in reasonable detail the nature of such default or breach (or reasonable efforts to cure such default or breach have not been commenced, if such default or breach is not reasonably capable of being cured within such one hundred and eighty (180) day period)( The City shall provide the Guarantor a copy of any notice to the Company under Section 4.02(c));
- (d) By the Company, if there has been a material default or breach by the City of any of the representations, warranties, covenants or agreements of the City contained in this Agreement and such default or breach shall not have been waived by the Company or cured by the City within one-hundred and eighty (180) days after receipt by the City of written notice from the Company specifying in reasonable detail the nature of such default or breach (or reasonable efforts commenced to cure such default or breach have not have been commenced, if such default or breach is not reasonably capable of being cured within such one hundred and

2015 SEP 10 PM 4 53

eighty (180) day period).

**Section 4.03. Reimbursement for Early Termination & Guaranty.**

(a) If this Agreement is terminated by the City pursuant to Section 4.02(c) within the first five (5) years of the Initial Term, the Company shall pay to IPL the total amount of IPL's Costs incurred as of the termination date, less the aggregate amount of the estimated initial thirty (30) months of retail electric revenue to IPL from each line extension put into service for the Locations as of that date, up to a maximum amount of Four Million Dollars (\$4,000,000.00) (the "Early Termination Payment"). Within thirty (30) days of receipt by the Company of documentation of IPL's Costs from the City and/or IPL, which documentation shall consist of the monthly budget reports provided by IPL under Section 2.04(d)(ii) and any supplementary documentation as is reasonably necessary for the Company to confirm the amount of IPL's Costs as of the termination date, the Company shall pay the Early Termination Payment to IPL.

(b) On or before the Effective Date, Bluecarsharing (the "Guarantor") shall have executed and delivered to IPL a Guaranty in the form attached to this Agreement as Exhibit F.

(c) The City will defend, indemnify, and hold harmless the Company from any claim by IPL to recover IPL's Costs over and above the Early Termination Payment amount in the event this Agreement is terminated as described in Section 4.03(a); provided that this indemnity will not apply to any claims made pursuant to any other section of this Agreement or on any other basis.

(d) In accordance with Section 8.07, IPL shall be entitled to the recovery of reasonable attorneys' fees and costs awarded in connection with any Proceeding instituted or shall be included in any settlement or other payment of the disputed amounts.

(e) After the fifth (5) year anniversary of the Effective Date and contingent upon satisfactory performance of the Company's payment obligations up until that time, the Company's and the Guarantor's obligations under this Section 4.03 shall be deemed terminated.

**Section 4.04. Location Fixtures.**

(a) Upon expiration or earlier termination of this Agreement, the City shall have the option (the "Option"), exercisable within ninety (90) days of the date of expiration or earlier termination of this Agreement (the "Option Period") by delivering written notice of exercise to the Company (the "Option Notice"), to purchase all (but not less than all) of the Location Fixtures for the Fair Market Value thereof.

(b) If the City delivers the Option Notice to the Company, the Company shall (i) not remove the Locations and (ii) shall, upon conclusion of the process provided in Section 1.01(v), sell the Location Fixture to the City for Fair Market Value.

(c) If the City fails to deliver an Option Notice within the Option Period or affirmatively elects to waive its Option, then, within sixty (60) days following the expiration of the Option Period, the Company shall remove and store, at the Company's sole cost and expense, all of the Location Fixtures, all of which shall be and remain the property of the Company.

(d) If the Company is required by Section 4.03 to pay the Early Termination Payment;

(i) Notwithstanding Section 4.04(a), the City shall have the Option, exercisable within ninety (90) days of the date such Early Termination Payment is received by IPL.

(ii) Notwithstanding Section 4.04(b), the Company shall not remove the Location Fixtures until such time as such Early Termination Payment is received by IPL.

(e) Subject to the limitations set forth in Section 8.07, the City shall be entitled to the recovery of reasonable attorneys' fees and costs for any Proceeding instituted to enforce this Section 4.04.

Section 4.05. Effect of Termination. Except as provided in this Section 4.05 and in Section 11.01, in the event this Agreement is terminated pursuant to Section 4.02, or expires pursuant to Section 4.01, all rights and obligations of the Parties shall terminate without any Liability of a Party to the other Party; *provided however*, that Articles VII, VIII, and IX and Sections 4.03, 4.04, 4.05, 4.06, 5.01, 5.02, 5.03, 12.02, 12.04, 12.05, 12.13, and 12.16, and any and all defined terms used in any of the foregoing provisions, and the rights and obligations of the Parties set forth therein, shall survive the termination of this Agreement indefinitely; provided further that, if this Agreement is terminated because of a breach of this Agreement by the non-terminating Party, the terminating Party's right to pursue all legal remedies shall survive such termination unimpaired.

Section 4.06. Offset of Early Termination Payment. To offset the costs incurred by the Company by paying the Early Termination Payment, the City shall, within thirty (30) days from the date the Early Termination Payment is received by IPL, issue a formal solicitation (e.g., a request for proposals) to determine the viability of entering into contract with a Person who could make productive use of the Locations. Prior to the release of the solicitation, the City shall invite the Company (subject to the negotiation and agreement on reasonable terms of a confidentiality agreement to protect the confidential nature of the solicitation and deliberations relating to the solicitation) to review, and provide feedback on, the formal solicitation prior to its release and potential award; provided however, the Company shall not be permitted to respond to the solicitation. The Parties agree to negotiate in good faith the amount of an offset to the costs incurred by the Company (which shall include the Early Termination Payment), which amount shall not exceed the amount of the Early Termination Payment nor exceed forty percent (40%) of the revenue to the City under the new contract during the three years of that contract. The City shall not negotiate terms of the contract to arbitrarily reduce said offset. The failure to agree to a refund amount shall be submitted to the dispute resolution procedures in Article IX.

**ARTICLE V.**  
**OTHER AGREEMENTS & COVENANTS**

**Section 5.01.**     **Name of the Services; Publicizing Services; Advertising.**

(a)     The name of the Services will be "BlueIndy". The Company will advertise in the local media to increase awareness of the Services.

(b)     Unless otherwise notified in writing, the Company has the express consent of the City for the use of its respective trademarks, trade names, service marks, service names, or any other intellectual property, all of which shall remain the sole and exclusive property of the City, in any such advertisements. This consent does not extend to the use of any of IPL's intellectual property, which use shall require IPL's express written consent to the Company.

(c)     Consistent with the City's commitment to contribute to the highest usage of the Service, the City will, as the City deems appropriate in its sole discretion, advertise the Services, including publicizing the Services on the City's website and through local and regional public transportation ads, literature and websites. Unless otherwise notified in writing, the City has the express consent of the Company for the use of its respective trademarks, trade names, service marks, service names, or any other intellectual property, all of which shall remain its sole and exclusive property of its respective owner, in any such publications or advertisements.

(d)     All trademarks, trade names, service marks, service names, and all other intellectual property rights associated with the Business, including, without limitation, the name "Bluecar", "BlueCarSharing", "BlueIndy" and any derivations thereof, shall be and remain the sole and exclusive property of the Company and its Affiliates as the case may be.

(e)     The Company may sell advertisements on or inside Vehicles, at the Locations, on its website, and its mobile applications so long as such advertisements are in compliance with the Law

**Section 5.02.**     **Profit Sharing & Rate Mitigation.**

(a)     Profit Sharing. Once the Company achieves Profitability, the Company shall pay fifteen percent (15%) of the Net Profit earned by the Company during each calendar year (the "Profit Share") to the City and IPL as further provided in this Section 5.02.

(b)     Delivery of Financial Statements to the City. Starting with the calendar year ending December, 31, 2015, the Company shall cause to be prepared and delivered to the City within ninety (90) days after the conclusion of each calendar year during the Term audited financial statements of the Company for each such year, certified by the Company and including the Company's calculation of the Net Profit (if any) for that year (the "Financial Statements").

(c)     Audit of the Profit Share.

(i)     If the City disagrees with the Company's calculation of Net Profit for any such calendar year, the City may, within forty-five (45) days after delivery of the Financial Statements, deliver a notice to the Company disagreeing

with such calculation and setting forth the City's calculation of such amount. Any such notice of disagreement shall specify those items or amounts as to which the City disagrees, and the City shall be deemed to have agreed with all other items and amounts contained in the Financial Statements and the calculation of Net Profit for the applicable calendar year.

- (ii) If a notice of disagreement is duly delivered, an officer of the Company and the City Representative shall, during the fifteen (15) days following such delivery, use their commercially reasonable efforts to reach agreement on the disputed items or amounts in order to determine, as may be required, the amount of Net Profit for the applicable calendar year. If such representatives so resolve all disputes, the computation of Net Profit, as amended to the extent necessary to reflect the resolution of the dispute, shall be conclusive and binding on the parties. If during such period, such representatives are unable to reach an agreement, they shall promptly thereafter cause the Independent Accountant to review this Agreement and the disputed items or amounts for the purpose of calculating Net Profit (it being understood that in making such calculation, the Independent Accountant shall be functioning as an expert and not as an arbitrator). In making such calculation, the Independent Accountant shall consider only those items or amounts in the Financial Statements related to the calculation of the Net Profit that is the subject of the City's disagreement.
- (iii) The Independent Accountant shall deliver to the Company and the City, as promptly as practicable (but in any case no later than thirty (30) days from the date of engagement of the Independent Accountant), a report setting forth such calculation. Such report shall be final and binding upon the Company and the City. The fees, costs and expenses of the Independent Accountant's review and report shall be allocated to and borne by the Company and the City based on the inverse of the percentage that the Independent Accountant's determination (before such allocation) bears to the total amount of the total items in dispute as originally submitted to the Independent Accountant. (For example, should the items in dispute total in amount to One Thousand Dollars (\$1,000) and the Independent Accountant awards Six Hundred Dollars (\$600) in favor of the City's position, sixty percent (60%) of the costs of its review would be borne by the Company and forty percent (40%) of the costs would be borne by the City.)

(d) Payment of the Profit Share. In accordance with Section 5.02, the Company shall pay the Profit Share on the earlier of (i) forty-five (45) days after the date the Financial Statements are delivered to the City if the City does not deliver a dispute notice within the forty-five (45) day dispute period or (ii) if the City does deliver a dispute notice within the forty-five (45) day dispute period, thirty (30) days after the Parties resolve the dispute on their own or the Independent Accountant delivers its determination, if the result of either is a determination that amounts are due to the City and/or IPL. The Profit Share is subject to set-off as otherwise set

forth in this Agreement.

(e) Company Obligations. The Company acknowledges and agrees that it will not take any action in bad faith in order to decrease the amount of Net Profit. The Company shall in good faith use its reasonable best efforts to maximize Net Profit. Without limiting the generality of the foregoing, the Company will:

- (i) Account for the Business as a separate accounting entity;
- (ii) Not permit any changes in the accounting methods used by the Company that could reasonably be expected to have a negative effect for the City and/or IPL on the calculation of their respective Profit Share;
- (iii) Use its reasonable best efforts to maintain good relationships with the customers of Company; and
- (iv) Operate the Company's business in a good faith manner such that Company will not take any action that has the effect of artificially decreasing or delaying the accrual of Net Profit during the Term.

Any alleged breach of these obligations shall be settled pursuant to the Dispute Resolution provisions in Article IX.

(f) Distribution of the Profit Share Between the City & IPL. In accordance with Section 5.02(a), the Company shall pay the entire Profit Share to IPL until the aggregate amount of the Profit Share paid during the Term reaches Four Million Dollars (\$4,000,000.00); after which time, the Company shall distribute two-thirds (2/3) of the Profit Share to IPL and one-third (1/3) to the City until the aggregate amount of the Profit Share paid during the Term reaches Ten Million Dollars (\$10,000,000.00); after which time, the Company shall distribute one-third (1/3) of the Profit Share to IPL and two-thirds (2/3) of the Profit Share to the City until IPL has been reimbursed fully for IPL's Costs, less the aggregate amount of the estimated initial thirty (30) months of retail electric revenue to IPL from each line extension put into service for the Locations, which reimbursement IPL will use for the sole purpose of mitigating the costs of IPL's Work reflected in IPL's retail rates. Thereafter and for the remainder of the Term, the Company shall distribute five percent (5%) of the Profit Share to IPL and ninety-five percent (95%) to the City. Notwithstanding the foregoing, the City acknowledges and agrees that the Company is not making any representation or guaranty as to achieving Profitability or, if Profitability is achieved, the amount of the Profit Share during the Term. The City shall cause IPL to notify the Company when IPL has been reimbursed fully for IPL's Costs less the aggregate amount of the estimated initial thirty (30) months of retail electric revenue to IPL from each line extension put into service for the Locations. In accordance with Section 8.07, the City is entitled to the recovery of reasonable attorneys' fees and costs awarded in connection with any Proceeding instituted or shall be included in any settlement or other payment of the disputed amounts.

(g) Reductions to the Profit Share. If, at the time of the next scheduled payment of the Profit Share, any amounts are owed by the City to the Company pursuant to this Agreement, then:

- (i) In the event that a Temporary Closure at any Location is longer than fourteen (14) days over the course of any one (1) calendar year, the Profit Share shall be reduced by the Temporary Closure Amount known at the time of such payment.
- (ii) If the City fails to make any repairs required by Section 3.01(b) within forty-five (45) days following receipt of notice from the Company that such repairs are necessary, the Company may, at its option (but with no obligation to do so), make such repairs which shall occur at the Company's reasonable cost and expense and not be reimbursed by the City unless the City and the Company agree otherwise in writing; *provided however*, that, if not agreed by the City, the Profit Share will be reduced by the amount of such costs and expenses.
- (iii) Should the Company be subjected to Exempt Taxes as described in Section 5.07, an amount equal to such Exempt Taxes shall be reduced from the Profit Share and, should that reduction be insufficient to offset the Exempt Taxes imposed on the Company, the Profit Share will be reduced by the amount of such Exempt Taxes.

When there is no Profit Share under Section 5.02(a) or when a reduction to the Profit Share is made pursuant to this Section 5.02(g) and the application of that reduction would result in the available Profit Share equaling zero (0), then the City shall, at the time when the Profit Share would be paid pursuant to Section 5.02(d), reimburse the Company for the difference between the available Profit Share and the costs associated with such reductions.

(h) Additions to the Profit Share. If, as provided under Section 3.01(b), the safe or proper functioning of the Services at the Locations (including any Location Fixtures) is unreasonably impaired for more than forty-five (45) days by reason of the negligence of, recklessness of, or willful misconduct by the Company, the Profit Share shall be calculated as if the affected Location were not unreasonably impaired and the amount for that Location shall be the average daily amount of gross sales over the most recent forty-five (45) days when the Location was fully operational. Notwithstanding the foregoing, if, in the Company's reasonable judgment, there are unique and special circumstances that prevent the Company from restoring the safe or proper functioning of the Services at such Location within such forty-five (45) day period (i.e. delays caused by an insurance adjuster or supply limitations for Charging Stations or Kiosks that cannot be mitigated by reasonable commercial efforts of the Company), the Parties will discuss delay and the forty-five (45) day period will be extended until the Company selects the earliest practical date to restore the safe or proper functioning of the Services at the affected Location.

(i) Temporary contribution of the City's share of the Profit Share. As part of the New Financial Structure described in Article XI, The City agrees that starting on the 6<sup>th</sup> anniversary of the Effective Date, its share (if any) of the Profit Share payable by the Company, after payment of IPL's share as set forth in Section 5.02.f, will be divided in half until the corresponding cumulative amount represented by such contribution reaches \$1,000,000.

Section 5.03. Reporting Requirements.

(a) The Company shall promptly make the City Representative aware of any prolonged or otherwise significant disruption to the Services, any significant customer complaints relating to the Services, any bodily injury to any Person relating to use of the Services, and any instance of property damage reasonably estimated to exceed Ten Thousand Dollars (\$10,000).

(b) On at least a quarterly basis, or more frequently as agreed between the Parties, the Company shall send to the City in a tabular, electronic format (such as Microsoft Excel) reports of customer usage at the Locations, including but not limited to the following:

- (i) The number of rentals per day;
- (ii) A graph of the number of rentals per Location per month;
- (iii) A list of the number of rentals per time of day;
- (iv) The average rental duration per month;
- (v) The average rental distance per month;
- (vi) The number of memberships at the end of each month; and
- (vii) The average number of rentals per vehicle per day.

(c) The Company shall provide to the City on at least a quarterly basis in a tabular, electronic format (such as Microsoft Excel) data sufficient to report on the use of the Services to charge private EVs, including but not limited to the number of transactions, number of memberships and average duration of transaction.

(d) The Company shall provide a construction forecast to the City and IPL on at least a quarterly basis showing the number and site of Central Business District ("CBD") and non-CBD Locations anticipated to be constructed in the following quarter with an estimated timeline for such construction.

(e) The Company shall cooperate with the City or IPL to assemble any information requested by the IURC or the Office of Utility Consumer Counselor regarding this Agreement and the Services within the time period required by such Governmental Entity. The Company shall have the right, at its expense, to seek a protective order or equivalent contesting the disclosure of that information.

(f) Within ninety (90) days of the end of its fiscal year, the Company shall deliver to the City an audited financial report for the Business and other such reports related to the Company as necessary for the City to confirm compliance with the Company's obligations relating to the Profit Share.

(g) Unless disclosure is required by applicable Law and except as provided in Section



12.13, the City shall keep confidential any information obtained from the Company under this Section 5.03; *provided however*, that the City shall have the right to disclose such information to IPL and to determine, in its reasonable discretion, whether applicable Law requires disclosure of any such information to any other third party; provided further, that in the event the City determines that applicable Law requires disclosure of such information, the City shall provide reasonable notice to, and shall consult with, the Company prior to disclosure of such information. This subsection (d) shall not apply to information which is already or, as a result of the Company's actions, becomes publicly available information. In the event that the Company requests the City to defend an action seeking the disclosure of information that the City determines to be confidential pursuant to this Section 5.03, the Company shall reimburse the City for the reasonable costs and expenses (including attorneys' fees) incurred by the City in defending any such action.

**Section 5.04.** **Insurance.** The Company shall at all times maintain a policy or policies of casualty insurance covering the Location Fixtures and the Vehicles. The Company agrees to procure and maintain during the Term a policy or policies of insurance written by a responsible insurance company or companies insuring the Company, subject to exclusions and limitations contained in the insurance policy but with exclusions and limitations no broader than in the current form of commercial general liability policy published by Insurance Services Office, Inc., against any and all losses, claims, demands or actions from injury to or death of any Person or damage to property. Such coverage shall be in limits of no less than \$10,000,000. All such policies shall include the City and IPL as additional insureds for damages attributable to the Company. The Company shall cause to be issued a certificate of insurance evidencing the insurance coverage required by this Section and the status of the City and IPL as additional insureds for damages attributable to the Company. Although the City and IPL shall be named as additional insureds, in no event shall either the City or IPL be subject to or liable for any self-insured retention or deductible; in the event any insurer issuing the insurance coverage required by this paragraph contends that either the City or IPL is obligated to pay any self-insured retention or deductible, the Company shall be responsible for paying that amount on behalf of the City and IPL. Upon written request from the City or IPL, the Company shall verify continued compliance with this Section. The insurance shall contain a waiver of subrogation clause, whereby the insurer thereunder waives any and all rights of subrogation against the City or IPL.

**Section 5.05.** **Utilities.** The Company shall pay when due all charges (including all applicable Taxes and fees) for communications, gas, electricity, light, heat, power, telephone, water and other utilities and services used at the Locations or necessary to provide the Services.

**Section 5.06.** **Temporary Closures of Locations.** Notwithstanding any other provision of this Agreement, at all times during the Term:

(a) The following may occur without notice or compensation to the Company and do not constitute Temporary Closures ("Emergency Closures"):

- (i) A closure or other action or inaction limiting customer use at a Location due to access or restrictions on access by any Governmental Entity with jurisdiction over the Locations, including any Personnel retained by or acting with authority on behalf of a Governmental Entity, to prevent or to

7p 10 PM 4 54

respond to a public safety emergency so long as such prevention is not otherwise related to a Temporary Closure.

- (ii) A closure or other action or inaction limiting customer use at a Location due to congested traffic or the incidental provision of services by a Governmental Entity or public utility, including but not limited to solid waste pickup, snow removal, towing, and repair and maintenance of utilities by a public utility.

In the event any Emergency Closure continues for more than fourteen (14) days in any calendar year, such excess days shall be considered Temporary Closures.

(b) The Parties acknowledge that Temporary Closures may be necessary for a variety of reasons, including special events, such as conventions and parades. The City shall be entitled to Temporary Closures of Locations by providing fourteen (14) days written notice to the Company unless the City does not have the necessary advance knowledge to provide such notice within that timeframe in which case the City shall provide notice as soon possible during normal business hours prior to the closure. After the Public Opening, no more than ten percent (10%) of the total Locations shall be closed at any one time due to Temporary Closures.

(c) The City shall ensure that police, fire and emergency services are familiar with the Business and have procedures in place to handle situations that may develop. The Company will cooperate with the City in establishing such procedures.

(d) Except as provided in this section, Personnel of any Governmental Entity are not permitted to park at Locations unless using the Services in accordance with the Customer Agreement.

(e) If access is limited to a Location by a third party in a manner not contemplated by this Section 5.06, the City shall assist the Company in resolving the issue to make the Location accessible to customers; *provided however*, the City is not responsible for any lost revenue or other damages to the Company for such closures.

#### Section 5.07. Taxes.

(a) Taxes of Other Governmental Entities. Nothing in this Agreement shall be construed to exempt the Company from Taxes from any Governmental Entity other than the City and Marion County, Indiana.

(b) City/County Taxation. Except as provided in Section 2.06, nothing in this Agreement shall be construed to exempt the Company from any Taxes from the City or Marion County, Indiana, except as provided as follows (hereinafter collectively "Exempt Taxes"):

- (i) Property Taxes on Real Property. In no event shall the Company be required to pay local property taxes on real property with respect to the Locations that are located on city-owned property or city-controlled public right of way.

- (ii) Parking Taxes. In no event shall the Company be required to pay Parking Taxes with respect to the Locations or for any costs associated with the City's removal of its parking meters to accommodate Locations.
- (iii) City Fees. Fees charged by the City's Department of Code Enforcement for permits and licenses shall be waived where possible or otherwise reimbursed to the Company by the City.
- (iv) Company-Specific Taxes. In no event shall the Company be subjected to any Tax imposed by the City or Marion County, Indiana, that has the effect of applying only to the Company or its Business.

Section 5.08. Minority-, Woman-, & Veteran- and Disabled Business Participation. To the extent the Company uses subcontractors in the performance of services under this Agreement, Company shall either:

(a) Use, at a minimum, fifteen percent (15%) Minority Business Enterprises, eight percent (8%) Women's Business Enterprises, three percent (3%) Veteran's Business Enterprises, and one percent (1%) Disabled Business Enterprises in the performance of services under this Agreement; or

(b) Demonstrate a good faith effort to achieve such percentages in compliance with the policies and to the satisfaction of the City of Indianapolis Department of Minority & Women Business Development.

(c) The Company shall report quarterly to the City on its obligations under this Section 5.08.

(d) A breach of this Section 5.08 shall not result in a termination event pursuant to Section 4.02(c).

Section 5.09. Updates to Exhibits C & D. The Parties acknowledge that, from time to time, the Company may desire to update Exhibits C and D, which the Company may do subject to the following provisions and with the written consent of the City and IPL, which consents shall not be unreasonably withheld.

(a) In no event shall the City be required to consent to a change to Exhibit C or Exhibit D that would have the effect of increasing the costs of the City's Work or altering the City's or IPL's responsibilities or obligations or IPL's Work. The City shall not amend the IPL Agreement without the Company's consent, which consent will not be unreasonably withheld, conditioned or delayed; and

(b) The Company may not change either Exhibit C or Exhibit D more than twice in any consecutive twelve (12) month period. Further, no change to Exhibit C or Exhibit D will be accepted by the City or by IPL unless IPL has determined such change is compatible with IPL's network.

Section 5.10. Ancillary Wireless Services.

(a) In addition to, and not by way of limitation of, any other rights conferred hereunder, the Parties agree that the Company may (but shall be under no obligation to) install, operate, maintain, and upgrade wireless networking equipment of the Company's choosing at any or all of the Locations for the purpose of providing wireless networking connectivity to its customers ("Ancillary Services"). Such wireless networking equipment shall be considered Location Fixtures.

(b) Any Ancillary Services shall be installed, operated, maintained, and upgraded in compliance with all Laws.

(c) If the installation, operation, maintenance, or upgrade of Ancillary Services would lead to a material change to the size of the area (such as through the addition of another structure, like a meter box, Charging Station, or Kiosk) or result in any material protrusion of antennae, the Company may not proceed with such installation, operation, maintenance, and upgrade.

(d) Sixty (60) days before to the initial operation of the Ancillary Services, the Company shall provide detailed plans to the City Representative.

(e) The City shall not be required to expend any funds whatsoever in support of Ancillary Services except as otherwise required by this Agreement to support the Services which are not Ancillary Services. The costs to install, operate, maintain, or upgrade Ancillary Services shall not be included in IPL's Costs or otherwise cause IPL's Costs to increase.

(f) The Exclusive Right shall have no application whatsoever to Ancillary Services except as otherwise required by this Agreement to support the Services which are not Ancillary Services.

(g) Ancillary Services shall not be included in the Profitability calculation under Section 5.02.

(h) If the Company proceeds with the installation of wireless networking equipment as described under this Section 5.10, the Company will install, operate, and maintain the wireless networking equipment in a manner that will not cause interference (including, but not limited to, radio frequency (RF) interference, mechanical interference or any interference with underground utilities) with the equipment of other Persons. In the event any such interference occurs, the Company will (i) remedy any interference within thirty-six (36) hours after receipt of notice from the City or (ii) cease operation of its wireless networking equipment until the interference can be eliminated.

**ARTICLE VI.**  
**REPRESENTATIONS & WARRANTIES OF THE CITY**

Section 6.01. City Representations. The City hereby represents and warrants to the Company, and intends that the Company rely, as follows:

(a) Authorization & Validity of this Agreement. The City has the legal capacity and

authority to enter into this Agreement and to carry out its obligations hereunder and to comply with and fulfill the terms and conditions of this Agreement. This Agreement has been duly executed and delivered by the City and constitutes the legal, valid, and binding obligation of the City enforceable against the City in accordance with its terms and conditions.

(b) No Conflict or Violation. The execution, delivery, consummation and performance of this Agreement by the City do not and shall not:

- (i) Violate any provision of Law applicable to the City;
- (ii) Violate or result in a breach of, cause acceleration, allow a party to modify or constitute (with or without due notice or the passage of time or both) a default (or give rise to any right of termination, cancellation, acceleration or modification or right of first refusal, right of first offer or other similar right) under the terms, conditions or provisions of any Contract to which the City is a party; or
- (iii) Violate or result in a breach of or constitute (with or without due notice or the passage of time or both) a default under any judicial consent, order or decree to which the City is a party or by which it is otherwise bound.

(c) Consents & Approvals. Except as provided in Article XI, the execution, delivery and performance of this Agreement by the City:

- (i) Does not require either Party to obtain the consent or approval of, or to make any filing with, any Governmental Entity except as may be required to obtain any permits or licenses required by applicable Law to be obtained in connection with the City's performance hereunder; and
- (ii) Does not require the City to obtain the consent or approval of, or to make any filing with any other Person.

(d) Title.

- (i) The City has good and sufficient title or control of the Locations on city-owned property and city-controlled public right of way necessary for the Company to perform the Services pursuant to this Agreement.
- (ii) No indebtedness for borrowed money of the City is or will be secured by any right or interest in the Locations and no judgment lien exists or shall exist in any revenue derived from or generated with respect to the Services.
- (iii) There is no recorded or unrecorded Contract, option, commitment, right, privilege or other right of another binding upon, or which at any time in the future may become binding upon, the City to sell, transfer, convey, subject to lien, charge, grant a security interest in, or in any other way dispose of or materially encumber the Locations.

(iv) The recorded or unrecorded restrictions, exceptions, easements, rights of way, reservations, limitations, interests and other matters that affect title to or the City's control of the Locations (or any portion thereof) do not materially adversely affect the Company's ability to perform the Services in accordance with the terms hereof.

(e) IPL's Work. The City shall cause IPL to perform IPL's Work as described in Exhibit I. The Parties acknowledge that certain obligations of the City under this Agreement will not be passed on to IPL in the IPL Agreement.

(f) IPL's Service Territory. The Parties acknowledge that it is possible that another electric utility may serve customers in Marion County, however, the City represents that (i) the map attached hereto as Exhibit G is IPL's current assigned service territory ("Assigned Service Territory"), which includes virtually all of Marion County, Indiana; and (ii) each Location listed in Exhibit A and Locations 26 to 70 listed in Exhibit B are within the Assigned Service Territory.

#### **ARTICLE VII. REPRESENTATIONS & WARRANTIES OF THE COMPANY**

Section 7.01. **Company Representations.** The Company hereby represents and warrants to the City, and intends that the City rely, as follows:

(a) Organization, Authorization & Validity of this Agreement. The Company is a limited liability company, duly formed and validly existing under the Laws of the State of Indiana. The Company has the legal capacity and authority to enter into this Agreement and to carry out its obligations hereunder and to comply with and fulfill the terms and conditions of this Agreement. This Agreement has been duly executed and delivered by the Company and constitutes the legal, valid and binding obligation of the Company enforceable against the Company in accordance with its terms and conditions.

(b) No Conflict or Violation. The execution, delivery, consummation and performance of this Agreement by the Company do not and shall not:

- (i) Violate any provision of Law applicable to the Company;
- (ii) Violate or result in a breach of, cause acceleration, allow a party to modify or constitute (with or without due notice or the passage of time or both) a default (or give rise to any right of termination, cancellation, acceleration or modification or right of first refusal, right of first offer or other similar right) under the terms, conditions or provisions of any Contract to which the Company is a party; or
- (iii) Violate or result in a breach of or constitute (with or without due notice or the passage of time or both) a default under any judicial consent, order or decree to which the Company is a party or by which it is otherwise bound.

(c) Approval of Exhibit C & Exhibit D. Within thirty (30) days of the execution of this Agreement by the Parties, the Company will cause Exhibit C and Exhibit D to have been

reviewed and stamped by a Professional Engineer licensed by the Indiana State Board of Registration for Professional Engineers. The Parties agree to work collaboratively to amend Exhibit C or Exhibit D as necessary to conform to the requirements of this section 7.01(c) and to do so in consultation with IPL. The City will request IPL to cause any drawings or specifications provided by IPL for insertion in Exhibit C or Exhibit D to be reviewed and stamped by a Professional Engineer licensed by the Indiana State Board of Registration for Professional Engineers within thirty (30) days following the Company's delivery of its final design of the Location Fixtures to the City and IPL; *provided however*, that IPL shall not be required to procure additional stamped drawings in the event the Company updates Exhibit C or Exhibit D as provided in Section 5.09.

### **ARTICLE VIII, INDEMNIFICATION**

**Section 8.01.** Indemnification by the City. To the maximum extent permitted by applicable Law, the City shall defend, indemnify, and hold harmless the Company and its successors, Personnel, representatives, Affiliates and agents (collectively, the "Company Indemnified Parties") from and against any Indemnity Losses arising from or relating to:

(a) Any action relating to the City's Work as a result of the City or its subcontractors' negligence, recklessness, or willful misconduct.

(b) The actual breach of any of the representations or warranties of the City contained herein;

(c) The failure of the City to perform any of its covenants or obligations contained in this Agreement;

(d) All Liabilities in connection with the obligations of the City under this Agreement (including the City's Work but not including any Liabilities arising from IPL's Work, which shall be dealt with as provided under Section 8.01(e), and not including any Liabilities caused by the negligence, recklessness, or willful misconduct of the Company Indemnified Parties);

(e) Notwithstanding any other provision of this Agreement, with respect to Liabilities arising from IPL's Work:

(i) The City warrants that IPL's Work will be performed in accordance with all applicable federal, state and local laws, rules, regulations, and codes.

(ii) As a result of the assignment of the Warranty, the Contractor warrants IPL's Work against defects in workmanship for a period of four (4) years from the Original Installation Date. In the event and to the extent IPL's performance of IPL's Work for a Location is reasonably determined to be defective, the Contractor warrants that the Contractor will re-perform such IPL's Work during normal business hours at no additional cost to the City or the Company; provided that (i) the Contractor is notified in writing of any such defective original Installation Services within forty-five (45) days of the Original Installation Date; or (ii) the Contractor is notified in

writing of any defect in the Installation Services occurring later in the warranty period within thirty (30) days of discovery of such defect; and in either case no charges for time and material used by others in making repairs or corrections to the Installation Services (other than subcontractors of the Contractor in connection with warranty work performed at the direction of the Contractor) will be paid by the Contractor unless agreed in advance in writing by the Contractor. This warranty for re-performance of IPL's Work determined to be defective is the sole remedy for the Company under this Agreement and the City's sole obligation under this Agreement. Location Fixtures that are subjected to accident, neglect, abuse, vandalism, misuse or disasters, including but not limited to fire, wind, lightning, and flood, are not covered by this warranty other than an accident caused by the Contractor.

- (iii) EXCEPT AS OTHERWISE SPECIFICALLY STATED HEREIN, THE CONTRACTOR, THE CITY AND IPL DISCLAIM ALL STATUTORY, ORAL, EXPRESS OR IMPLIED WARRANTIES, INCLUDING WARRANTIES OF HABITABILITY, MERCHANTABILITY OR FITNESS FOR A PARTICULAR PURPOSE AND WARRANTIES ARISING FROM COURSE OF DEALING OR TRADE USAGE.

(f) Any and all Proceedings, demands, assessments, audits or judgments arising out of the foregoing.

Section 8.02. Indemnification by the Company. The Company shall defend, indemnify, and hold harmless the City and IPL and their respective representatives, Affiliates and agents (collectively, the "City Indemnified Parties") from and against any and all Indemnity Losses arising from or relating to:

- (a) Any action (or inaction) relating to customer use of the Services.
- (b) The actual breach of any of the representations or warranties of the Company contained herein;
- (c) The failure of the Company to perform any of its covenants or obligations contained in this Agreement;
- (d) Any claims from third parties arising out of the Company's operation of the Business (except for claims attributable to the negligent performance of any of the City's Work and/or claims that the process through which the Parties entered into this Agreement failed to satisfy any requirements of Law);
- (e) Any claims that any of the Business, Services, or Location Fixtures violate the intellectual property of any Person; and
- (f) Any and all Proceedings, demands, assessments, audits or judgments arising out of the foregoing.



Section 8.03. Indemnification Notice; Litigation Notice.

(a) If a Party entitled to defense and indemnity pursuant to Sections 8.01 or 8.02 (the "Claimant") believes that it has suffered or incurred any Indemnity Loss, it shall so notify the Party which the Claimant believes has an obligation to defend and indemnify the Claimant (the "Indemnifying Party") promptly in writing describing such Indemnity Loss in reasonable detail, the amount thereof, if known, and the method of computation of such Indemnity Loss, all with reasonable particularity (the "Indemnification Notice").

(b) If any Proceeding is instituted by or against a third party with respect to which the Claimant intends to claim any Liability or expense as an Indemnity Loss under this Article VIII, the Claimant shall promptly notify the Indemnifying Party in writing of such Proceeding describing such Indemnity Loss, the amount thereof, if known, and the method of computation of such Indemnity Loss, all with reasonable particularity (the "Litigation Notice"), in lieu of an Indemnification Notice.

(c) To the extent failure to promptly notify the Indemnifying Party of such action or suit can reasonably be deemed to increase the Liability or expense to the Claimant, the Indemnifying Party shall not be obligated to reimburse Claimant for the amount of such increase in Liability or expense.

Section 8.04. Defense of Third Party Claims.

(a) The Indemnifying Party shall have thirty (30) days after receipt of the Litigation Notice to notify the Claimant that it acknowledges its obligation to defend, indemnify, and hold harmless the Claimant with respect to the Indemnity Loss set forth in the Litigation Notice and that it elects to conduct and control any Proceeding with respect to an identifiable claim (the "Election Notice").

(b) If the Indemnifying Party gives a Disagreement Notice or does not give the foregoing Election Notice during such thirty (30) day period, the Claimant shall have the right (but not the obligation) to defend, contest, settle or compromise such Proceeding in the exercise of its reasonable discretion; *provided however*, that the right of the Claimant to indemnification hereunder shall not be conclusively established thereby.

(c) If the Indemnifying Party timely gives the foregoing Election Notice, the Indemnifying Party shall have the right to undertake, conduct and control, at the Indemnifying Party's sole expense, the conduct and settlement of such Proceeding, and the Claimant shall cooperate, including providing access to records and Personnel, with the Indemnifying Party in connection therewith; *provided however*, that:

- (i) The Indemnifying Party and the Claimant shall exercise their responsibilities under this Section 8.04 in good faith;
- (ii) The Indemnifying Party shall not consent to the imposition of any injunction against the Claimant without the prior written consent of the Claimant;

- (iii) The Indemnifying Party shall not settle a claim without the prior written consent of the Claimant unless the sole relief provided is monetary in nature and does not include any finding or admission of a violation by the Claimant of any Law or any Person's rights;
- (iv) The Indemnifying Party shall permit the Claimant to participate in such conduct or settlement through legal counsel chosen by the Claimant, but the fees and expenses of such legal counsel shall be borne by the Claimant;
- (v) Upon a final determination of such Proceeding, the Indemnifying Party shall promptly reimburse the Claimant, to the extent required under this Article VIII, for the full amount of any Indemnity Loss incurred by the Claimant, except fees and expenses of legal counsel that the Claimant incurred pursuant to clause (ii) above;
- (vi) The Indemnifying Party shall have the right to pay or settle any action or suit provided the Claimant has no Liability with respect to such settlement; and
- (vii) The Claimant shall have the right to pay or settle any such Proceeding; *provided however*, that in the event of a payment or settlement pursuant to clause (iv), the Claimant shall waive any right to indemnity therefor by the Indemnifying Party and no amount in respect thereof shall be claimed as an Indemnity Loss under this Article VIII.

**Section 8.05.** **Disagreement Notice.** If the Indemnifying Party does not agree that the Claimant is entitled to full reimbursement for the amount specified in the Indemnification Notice or the Litigation Notice, as the case may be, the Indemnifying Party shall notify the Claimant (the "Disagreement Notice") within thirty (30) days of its receipt of the Indemnification Notice or the Litigation Notice, as the case may be. Any dispute regarding the Indemnification provisions of this Article VIII shall be resolved as provided for in Article IX.

**Section 8.06.** **Payment of Indemnity Losses.** The Indemnifying Party shall pay to the Claimant the amount to which the Claimant may become entitled by reason of the provisions of this Article VIII within thirty (30) days after such amount is finally determined either by mutual agreement of the Parties or pursuant to the dispute resolution process set forth in Article IX or, in the case of an Indemnity Loss described in any Litigation Notice, the date on which both such amount and Claimant's obligation to pay such amount have been determined by a final, non-appealable judgment of the court or administrative body having jurisdiction over such Proceeding.

**Section 8.07.** **Limitation of Damages.** Neither Party shall be liable to the other for any Indemnity Losses suffered hereunder in excess of Three Million Dollars (\$3,000,000.00) in the aggregate; *provided however*, the Parties acknowledge and agree that the following are not included in, nor otherwise subject to, the foregoing cap on Indemnity Losses:

- (a) The Early Termination Payment;

(b) Any amounts owed under the Profit Share as provided in Section 5.02; and,

(c) Claims that any of the Business, Services, or Location Fixtures violates the intellectual property of any Person.

Furthermore, damages from a third party claim that is insured by the Company pursuant to Section 5.04 shall not be subject to the foregoing cap on Indemnity Losses to the extent of the policy limits.

## **ARTICLE IX. DISPUTE RESOLUTION**

**Section 9.01.** **Scope.** Any dispute arising out of, relating to, or in connection with this Agreement, including any question as to whether such dispute is subject to arbitration, shall be resolved as set forth in this Article IX.

**Section 9.02.** **Informal Dispute Resolution.** The Parties shall attempt in good faith to resolve such dispute within fourteen (14) days following receipt by one Party of notice of such dispute from the other Party. Statements made by representatives of the Parties during the dispute resolution procedures set forth in this Section 9.02 and in Section 9.03 and documents specifically prepared for such dispute resolution procedures shall be considered part of settlement negotiations and shall not be admissible as evidence in any arbitration or other litigation proceeding between the Parties without the mutual consent of the Parties.

**Section 9.03.** **Mediation.**

(a) Mediation of a dispute under this Agreement may not be commenced until the earlier of:

- (i) Such time as both Parties, after following the procedures set forth in Section 9.02, conclude in good faith that amicable resolution through continued negotiation of the matter does not appear likely; or
- (ii) Fourteen (14) days after the notice of the dispute is received pursuant to Section 9.02.

If, after such time period, the dispute remains unresolved, the Parties shall attempt to resolve the dispute through mediation.

(b) The mediator for such dispute shall be an attorney in good standing with the Indiana Supreme Court who is registered with the Indiana Supreme Court Commission for Continuing Legal Education as a civil mediator (the "Mediator"). The Parties shall attempt in good faith to agree on a Mediator.

(c) If the Parties cannot so agree within fourteen (14) days after it is determined that the Parties cannot resolve the dispute, the Parties jointly shall petition the Judge of the Marion County Circuit Court to order a list of five (5) qualified mediators from which the Parties shall strike. The claiming Party shall strike first. After striking is complete, the remaining individual

shall serve as Mediator. In the event the Mediator selected by striking is unable or unwilling to serve or is otherwise disqualified, the previously stricken mediators shall be designated in inverse order until a mediator is selected.

(d) Mediation shall be regarded as settlement negotiations as provided in Rule 2.11 of the Indiana Rules of Alternative Dispute Resolution.

**Section 9.04. Arbitration.**

(a) Unless the Parties otherwise agree, if mediation as set forth in Section 9.03 does not resolve the dispute, the dispute shall be exclusively and finally settled by arbitration in accordance with the Commercial Arbitration Rules of the American Arbitration Association (the "AAA Rules") in effect at the time of execution of this Agreement as modified or supplemented by this Article 9. Either Party may initiate the arbitration, as provided in the AAA Rules, no later than sixty (60) days after the date the mediator is selected. If the Parties mutually agree to extend the period for mediation, the sixty (60) day period for the initiation of arbitration shall be extended for an equal period of time. The place of arbitration shall be Indianapolis, Indiana unless the Parties agree otherwise.

(b) The arbitration panel shall determine the rights and obligations of the Parties in accordance with the substantive laws of the State of Indiana without regard to conflicts of laws principles thereof. Except as agreed by the Parties, the arbitration panel shall have no power to alter or modify any terms or provisions of this Agreement, or to render any award that, by its terms or effects, would alter or modify any term or provision of this Agreement. The arbitration panel shall have no power or jurisdiction to award punitive damages.

(c) The arbitration panel shall be composed of three arbitrators, one to be selected by the City, one to be selected by the Company and the third (who shall act as chairman of the panel) to be selected by the two previously-selected arbitrators. Each arbitrator shall be a lawyer admitted to practice law for a minimum of fifteen years who is in good standing in the State of his or her admission. If the two previously-selected arbitrators cannot agree on the selection of the third arbitrator, the Chief Judge of the United States Court of Appeals for the judicial circuit in which Indianapolis is located shall select the third arbitrator. A Party may contact potential arbitrators in the course of selecting its Party appointed arbitrator for the purpose of determining qualification, potential conflicts, availability, hourly rates and related matters. However, once the arbitration panel has been composed, the arbitrators shall act as neutrals and not as party arbitrators, and no Party shall engage in any ex parte communication with any member of the arbitration panel. The arbitration proceeding shall be recorded by a court reporter mutually satisfactory to the Parties.

(d) The Parties shall be entitled to discover all documents and information reasonably necessary for a full understanding of any legitimate issue raised in the arbitration. The Parties may use all methods of discovery available under the Federal Rules of Civil Procedure subject to time limits set by the arbitration panel. Each Party shall be entitled to take five depositions in addition to expert depositions and such additional depositions as may be permitted by the arbitration panel. Prior to the deposition of any expert witness, the party proposing to call such a witness shall provide a full and complete report by the expert, together with the expert's

calculations and other data by which the expert reached any opinions concerning the subject matter of the arbitration. The report shall be provided no more than ten (10) days prior to the date set forth in the expert witness's deposition.

(e) Each Party shall bear its own attorney fees, expenses, and costs. The award shall be a reasoned award within the meaning of Rule 42 of the AAA Rules and shall set forth findings of fact and conclusions of law. The award shall be in writing and state the reasons upon which it is based. The award shall be final and binding on the Parties. Judgment on the award may be entered by any court with jurisdiction.

(f) The Federal Arbitration Act, 9 U.S.C. § 1 et seq., shall govern any arbitration conducted pursuant to this Section 9.4. In addition to the grounds for modifying or correcting the award set forth in § 11 of the Act, the Court may modify or correct the award to the extent the arbitrators' erred in their findings as to Indiana Law and such error materially affected the arbitration award.

Section 9.05. Provisional Remedies. No Party shall be precluded from initiating a proceeding in a court of competent jurisdiction for the purpose of obtaining any emergency or provisional remedy to protect its rights that may be necessary and that is not otherwise available under this Agreement, including temporary and preliminary injunctive relief and restraining orders.

## **ARTICLE X. COMPLIANCE WITH LAWS**

### Section 10.01. Compliance with Laws.

(a) The Company agrees to comply with all Laws applicable to the Company in performing work pursuant to this Agreement (including but not limited to, those relating to discrimination in employment), conflicts of interest, prevailing wages, public notice, accounting records and requirements.

(b) The Mayor's Executive Order Number 1, 1987, and The Plan for Business Equality in Indianapolis Government as well as Section 581-101 of the Revised Code of the Consolidated City and County are hereby incorporated by reference and made as fully a part of this Agreement as if set out herein.

(c) The Law of the State of Indiana shall govern the creation, interpretation, construction and enforcement of, and the performance under, this Agreement and all transactions and agreements contemplated hereby, as well as any and all claims arising out of or relating in any way to this Agreement, notwithstanding the choice of Law rules of any state or jurisdiction.

### Section 10.02. Non-Discrimination.

(a) The Company certifies for itself and all its subcontractors compliance with existing Laws of the State of Indiana and the United States regarding prohibition of discrimination in employment practices on the basis of race, sex, creed, color, religion, national origin, ancestry, age, handicap, disabled veterans status and Vietnam-era veteran status.

(b) The Company and any subcontractors shall not discriminate against any employee or applicant for employment, to be employed in the performance of this Agreement, with respect to hire, tenure, terms, conditions, or privileges of employment, or any matter directly or indirectly related to employment, because of race, sex, creed, color, religion, national origin, ancestry, age, handicap, disabled veterans status and Vietnam-era veteran status.

**Section 10.03. Federal Non-Discrimination Laws.** The Company shall comply with all applicable federal Laws regarding non-discrimination, including:

(a) The Civil Rights Act of 1964, 42 U.S.C. § 2000 et seq. (1981) and the Civil Rights Act of 1991, P.L. 102 166;

(b) Executive Order Number 11246, 30 Fed. Reg. 12,319 (1965), reprinted in 42 U.S.C. § 2000(e) note, as amended by Executive Order Number 11375, 32 Fed. Reg. 14,303 (1967) and by Executive Order Number 12086, 43 Fed. Reg. 46,501 (1978);

(c) The Age Discrimination Act, 42 U.S.C. §§ 6101 6106 (1981) and the Age Discrimination in Employment Act, 29 U.S.C. §§ 621 34 (1967);

(d) The Rehabilitation Act of 1973, 29 U.S.C. §§ 793 794 (1981); and

(e) The Americans with Disabilities Act, 42 U.S.C. § 12101 et seq. (1990).

**Section 10.04. Drug-Free Workplace Certification.** The Company hereby covenants and agrees to make a good faith effort to provide and maintain a drug-free workplace. The Company will give written notice to the City within ten (10) days after receiving actual notice that the Company or an employee of the Company has been convicted of a criminal drug violation occurring in the Company's workplace. The Company must at all times at its own cost and expense observe and comply, in all material respects, with all applicable Laws now existing or later in effect that are applicable to it or the Services, including those Laws expressly enumerated in this Article X, and those that may in any manner apply with respect to the performance of the Company's obligations under this Agreement. The Company must notify the City within seven (7) days after receiving notice from a Governmental Entity that the Company may have violated any Laws as described above.

**Section 10.05. Regulations on Public Vehicles for Hire.** The City acknowledges that the Services and customer use thereof do not involve the provision of public vehicles for hire, as that term is defined in Section 996-11 of the Revised Code of the Consolidated City of Indianapolis and Marion County as of the Effective Date of this Agreement.

**Section 10.06. Future Laws.** Should Laws change after the Effective Date in a manner as to materially impact the ability of the Company to profitably operate its Services, the Company shall notify the City of the problem and enter into good faith discussions with the City to try to alleviate the impact of those changes to the Law.

**ARTICLE XI.**  
**NEW FINANCIAL STRUCTURE**

**Section 11.01.** In consideration for the reduced scope of the City's Work and IPL's Work included in this restated Agreement and the higher costs to the Company resulting from the IURC Order, the City agrees to:

- (a) Execute the Escrow Agreement in Exhibit H without change before May 15, 2015.
- (b) On or before September 1, 2015, deposit Six Million Dollars (\$6,000,000) into the Escrow Account.
- (c) Reduce its share of profit sharing in years 6 to 15 as set forth in Section 5.02.i.
- (d) Entitle the Company to the recovery of reasonable attorneys' fees and costs for any Proceeding instituted to enforce this Section 11.01.

**ARTICLE XII.**  
**MISCELLANEOUS**

**Section 12.01.** **Public Announcements.** Unless otherwise notified in writing, the Parties are deemed to have each other's approval to issue, or permit any agent or Affiliate to issue, any press release and to otherwise make, or permit any agent or Affiliate to make, any public statements relating to this Agreement; *provided however*, the Parties, or their agents or Affiliates, as applicable, shall not issue a press release or make any public statement relating to this Agreement without consulting the other Party unless the Party, or its agent or Affiliate, does so with the good faith belief that doing so is necessary to comply with applicable Law; and further provided that IPL's express written consent is required prior to the use of its name, logo, or any of its other intellectual property or any reference to IPL in any press release or public statement.

**Section 12.02.** **Costs & Expenses.** Whether or not the transactions contemplated by this Agreement are consummated, except as otherwise expressly provided herein, each of the Parties shall bear all expenses and costs incurred by such Party in connection with this Agreement and the transactions contemplated hereby, including, without limitation, the fees and disbursements of any legal counsel, independent accountants or any other Person or representative whose services have been used by such Party.

**Section 12.03.** **Further Assurances.** From and after the Effective Date, the Parties shall cooperate reasonably with each other and their respective subcontractors in connection with any steps necessary or desirable to be taken as part of their respective obligations under this Agreement, and shall:

- (a) Furnish upon request to each other such further information;
- (b) Execute and deliver to each other such other documents; and

2015 SEP 10 PM 4 54

(c) Do such other acts and things, all as the other Party may reasonably request for the purpose of carrying out the intent of, and the transactions contemplated by, this Agreement.

**Section 12.04. Addresses for Notices, Etc.** All notices, requests, demands and other communications that are required or permitted to be given pursuant to the terms of this Agreement shall be in writing, and delivery shall be deemed sufficient in all respects and to have been duly given as follows:

(a) On the actual date of service if delivered personally;

(b) On the third day after mailing if mailed by first class mail return receipt requested, postage prepaid and properly addressed; or

On the day after delivery to a nationally recognized overnight courier service during its business hours or the Express Mail service maintained by the United States Postal Service during its business hours for overnight delivery against receipt, in each case addressed or transmitted, as applicable, as follows:

If to the City:

Office of Corporation Counsel  
Attention: Corporation Counsel  
200 East Washington Street Suite 1601  
Indianapolis, Indiana 46204

With a copy to (which copy shall not constitute notice hereunder):

Office of the Mayor  
Attention: Chief of Staff  
200 East Washington Street Suite 2501  
Indianapolis, Indiana 46204

If to the Company:

Ice Miller LLP  
One American Square, Suite 2900  
Indianapolis, Indiana 46282-0200  
Attention: Michael E. Millikan

Except as otherwise provided in this Agreement, notice shall not be given by facsimile or electronic mail.

Any Party may change its address or other contact information for notice by giving notice to each other Party in accordance with the terms of this Section 12.04.

**Section 12.05. Third-Party Beneficiaries.** IPL is a third-party beneficiary under this Agreement only with respect to the enforcement of Sections 4.03, 5.01 and 5.04 and Exhibit F and the last paragraph of Section 2.03(a)(i). The Parties do not otherwise intend the benefits of this Agreement to inure to any other third party, and, except as provided in this Section 12.05, nothing contained in this Agreement shall be construed as creating any right, claim or cause of action in favor of any other such third party against either of the Parties. The Company acknowledges that neither this Agreement nor the IPL Agreement create any rights in favor of the Company from IPL or any obligations of IPL to the Company. The City agrees to guarantee the performance of IPL's Work under this Agreement.



**Section 12.06. Headings.** The article, section and paragraph headings in this Agreement are for reference purposes only and shall not affect the meaning or interpretation of this Agreement.

**Section 12.07. Construction.**

(a) The Parties have participated jointly in the negotiation and drafting of this Agreement, and, in the event of an ambiguity or a question of intent or a need for interpretation arises, this Agreement shall be construed as if drafted jointly by the Parties and no presumption or burden of proof shall arise favoring or disfavoring any Party by virtue of the authorship of any of the provisions of this Agreement.

(b) Words of any gender used in this Agreement shall be held and construed to include any other gender; words in the singular shall be held to include the plural, and words in the plural shall be held to include the singular, unless and only to the extent the context indicates otherwise.

(c) "Hereunder," "hereof," "hereto," "herein," and words of similar import shall be deemed references to this Agreement as a whole and not to any particular article, section or other provision hereof.

(d) "Including" (and with correlative meaning "include") means including without limiting the generality of any description preceding such term.

(e) "Or" is used in the inclusive sense of "and/or."

(f) In the event of a conflict between this instrument and any of its exhibits, the terms of this instrument shall control and govern.

**Section 12.08. References.** References to documents, instruments or agreements shall be deemed to refer as well to all addenda, appendices, exhibits, schedules, amendments, modifications or supplements thereto.

**Section 12.09. Severability.** The invalidity or unenforceability of any provision of this Agreement shall in no way affect the validity or enforceability of any other provision of this Agreement. Wherever possible, each provision hereof shall be interpreted in such a manner as to be effective and valid under applicable Law. In case any one or more of the provisions contained in this Agreement shall, for any reason, be held to be invalid, illegal or unenforceable in any respect, such provision or provisions shall be ineffective to the extent, but only to the extent, of such invalidity, illegality or unenforceability, without invalidating the remainder of such invalid, illegal or unenforceable provision or provisions or any other provisions hereof or thereof, as applicable, unless such a construction would be unreasonable. The Parties further agree to make a good faith effort to replace any such invalid or unenforceable provisions with valid and enforceable provisions designed to achieve, to the extent possible, the business purposes and intent of such invalid and unenforceable provisions.

**Section 12.10. Entire Agreement & Amendment.** This Agreement, including the exhibits referred to and incorporated by reference herein, contain the entire understanding of the

Parties with respect to the subject matter of this Agreement and the Original Agreement, as amended. There are no representations, promises, warranties, covenants or undertakings other than those expressly set forth in or provided for in this Agreement. This Agreement supersedes all prior agreements and understandings (written or oral) among the Parties with respect to the transactions contemplated by this Agreement. This Agreement may not be amended, supplemented, or otherwise modified except by a written agreement executed by the Company and the City.

**Section 12.11. No Waiver; Cumulative Remedies.** Except as specifically set forth herein, the rights and remedies of the Parties are cumulative and not alternative. No failure or delay on the part of any Party in exercising any right, power or remedy under this Agreement shall operate as a waiver of such right, power or remedy, and no single or partial exercise of any such right, power or remedy shall preclude any other or further exercise of such right, power or remedy or the exercise of any other right, power or remedy. To the maximum extent permitted by applicable Law: (a) no claim or right arising out of this Agreement can be discharged by one Party, in whole or in part, by a waiver or renunciation of the claim or right unless in writing signed by the other Party; (b) no waiver that may be given by a Party shall be applicable except in the specific instance for which it is given; and (c) no notice to or demand on one Party shall be deemed to be a waiver of any obligation of that Party or of the right of the Party giving such notice or demand to take further action without notice or demand as provided in this Agreement.

**Section 12.12. Successors & Assigns; Assignment.** This Agreement shall be binding upon and inure to the benefit of each of the Parties and their respective successors and permitted assigns. The Company shall not have the right to assign or delegate its rights or duties hereunder, in whole or in part, without the prior written consent of the City, which will not be unreasonably withheld if such assignment is to an Affiliate reasonably qualified to carry out the Company's obligations under this Agreement and acceptable to the Guarantor.

**Section 12.13. Confidentiality.** The Non-Disclosure Agreement with effective date of May 30, 2013 entered into by and between IER, IPL, and the City, as amended, shall govern the confidentiality obligations of the Parties and is hereby incorporated by reference.

**Section 12.14. Independent Contractor.** The relationship created by this Agreement between the Company and the City shall be that of independent contractors. Nothing contained in this Agreement shall be construed to imply a joint venture, partnership or principal-agent relationship between the Parties. Neither party shall have the authority to enter into Contracts or assume obligation for or on behalf of the other party.

**Section 12.15. Force Majeure.** Any failure of performance by a Party to this Agreement shall not constitute default hereunder if and to the extent caused by Force Majeure, which is defined to be occurrences beyond the reasonable control of a party, including but not limited to, acts of governmental authority, acts of God, strikes or labor disputes (except of a party's own workforce), fires, floods, explosions, riots, war, rebellion, insurrection and sabotage. The Party affected by a force majeure event shall provide written notice to the other party within fourteen (14) days, describing in detail the force majeure event and its expected impact on performance of obligations under this Agreement, along with the affected Party's plan to mitigate such impact. Upon written agreement of the Parties, the time for performance of this

Agreement shall be equitably extended as reasonably made necessary by the impact of the force majeure occurrence; provided that the affected party has used and continues to use all reasonable means available to mitigate any impact of the force majeure event. Under no circumstances will additional costs encountered by any Party due to a force majeure event be chargeable to the other party.

Section 12.16. Court Proceedings.

(a) Jurisdiction & Venue.

- (i) Subject to Article IX, any Proceeding permitted by the terms of this Agreement to be filed in a court, which Proceeding is brought to enforce, challenge or construe the terms or making of this Agreement, and any claims arising out of or related to this Agreement, shall be exclusively brought and litigated in a federal court having subject matter jurisdiction and located in Indianapolis, Indiana, unless, and only unless, such court does not have subject matter jurisdiction, in which case a Proceeding brought to enforce, challenge or construe the terms or making of this Agreement, and any claims arising out of or related to this Agreement, may be brought and litigated in state court located in any of the counties adjacent to Marion County, Indiana (but not Marion County).
- (ii) For the purpose of any Proceeding instituted with respect to any claim arising out of or related to this Agreement, each Party hereby irrevocably submits to the exclusive jurisdiction of a federal court having subject matter jurisdiction and located in Indianapolis, Indiana, unless, and only unless, such court does not have subject matter jurisdiction, in which case each Party hereby irrevocably submits to the jurisdiction of a state court located in any of the counties adjacent to Marion County, Indiana (but not Marion County).
- (iii) Each Party hereby irrevocably waives any objection or defense which such Party may now or hereafter have of improper venue, forum non conveniens or lack of personal jurisdiction.
- (iv) Each Party further irrevocably consents to the service of process out of such courts by the mailing of a copy thereof, by registered mail, postage prepaid, to the Party at the address set forth in Section 12.04 and agrees that such service, to the fullest extent permitted by applicable Law,
  - (A) Shall be deemed in every respect effective service of process upon such Party in any Proceeding arising out of or related to this Agreement and
  - (B) Shall be taken and held to be valid personal service upon and personal delivery to such Party. Nothing herein contained shall affect the right of each Party to serve process in any other manner permitted by applicable Law.

(b) Waiver of Jury Trial. To the fullest extent not prohibited by applicable Law, the prohibition of which cannot be waived, for any Proceeding which is permitted under this Agreement to be filed in a court, each Party hereby expressly and irrevocably waives any right to a trial by jury in such Proceeding, including, but not limited to, those Proceedings to enforce or defend any rights under this Agreement or under any amendment, consent, waiver, instrument, document or agreement delivered or which may in the future be delivered in connection herewith or arising from any relationship existing in connection with this Agreement. Each Party agrees that in any such Proceeding, the matters shall be tried to a court and not to a jury.

Section 12.17. Non-Collusion. By signing this Agreement, the Company duly swears, affirms, and warrants that it is the contracting party, and that it has not, nor has any other Affiliate, Personnel, member, representative, or agent of the firm, company, corporation, or partnership represented by it, directly or indirectly entered into or offered to enter into any combination, collusion or agreement to receive or pay any sum of money or other consideration for the execution of this Agreement other than that which appears upon the face of this Agreement.

Section 12.18. Conflict of Interest. The Company certifies and warrants to the City that neither it nor any of its Affiliates, Personnel, agents, or representatives who will participate in any way in the performance of the Company's obligations hereunder has or will have any conflict of interest, direct or indirect, with the City during the performance of this Agreement.

Section 12.19. Counterparts. This Agreement may be executed in multiple original, facsimile or electronic counterparts, each of which will be deemed an original, all of which when taken together shall constitute one and the same agreement.

IN WITNESS WHEREOF, the Parties hereto have caused this Agreement to be executed as of the Effective Date.

**"COMPANY"**  
BLUEINDY, LLC

**"CITY"**  
CITY OF INDIANAPOLIS

By:   
Printed: Herve Muller  
Title: President

By:   
Printed: David Roseberry  
Title: Deputy Chief of Staff

Approved for Availability of Funding  
City of Indianapolis

Approved for form and legality  
City of Indianapolis

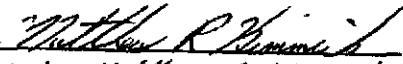
By:   
Printed: Matthew R. Kinnick  
Title: Controller

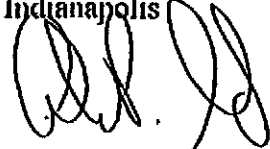
By:   
Printed: Andrew P. Stewart  
Title: 3-31-15

2015 SEP 10 PM 4 55  
PM 4 55

2015 JUL 20 PM 10 15

**EXHIBIT A**  
**PHASE ONE LOCATIONS**

**Locations 1 to 25**

| <b>Location</b> | <b>Name</b>                        | <b>Address</b>                    | <b>Areas/Key Features of Service</b>  |
|-----------------|------------------------------------|-----------------------------------|---|
| 1               | Monument Circle                    | 100 block E. Washington           | City Center   |
| 2               | Convention Center 1                | 100 S Capitol Ave.                | Convention Center & Georgia street  |
| 3               | City Market                        | 110 N Delaware St.                | City Market and City County Building  |
| 4               | Indianapolis International Airport | 7800 Col H Weir Cook Memorial Dr. | Indianapolis International Airport  |
| 5               | Monument Circle                    | TBD                               | City Center   |
| 6               | Ohio & Penn                        | 30 E Ohio St.                     | Chase tower and surrounding buildings   |
| 7               | IUPUI - Student Center             | 920 W Vermont St.                 | IUPUI commuting students  |
| 8               | Mass Ave 2                         | 480 Massachusetts Ave.            | Location of many restaurants and shops downtown   |
| 9               | Broad Ripple 1                     | 6280 N College Ave.               | Area with many restaurants and shops as well as residential area for many young professionals |
| 10              | Fountain Square                    | 1060 Virginia Ave.                | Location of many restaurants and shops downtown   |
| 11              | City Way                           | 210 E South St.                   | Serves City Way and Eli Lilly   |
| 12              | Illinois & Washington              | 8 North Illinois St.              | Located near several large hotels in the heart of downtown                                    |
| 13              | City County Building               | 240 E Washington St.              | City government building.   |
| 14              | White River State Park             | 801 W Washington St.              | Located downtown with many museums and attractions nearby                                     |
| 15              | Statehouse East                    | 110 N Capitol Ave.                | State government building   |
| 16              | Ivy Tech                           | 20 W 26th St.                     | Commuter campus near downtown   |
| 17              | Irvington                          | 5690 E Washington St.             | Up and coming neighborhood with many restaurants and shops                                    |
| 18              | SoBro 1                            | 5410 N College Ave.               | Neighborhood with many restaurants and young professionals                                    |
| 19              | Butler University                  | 704 W Hampton Dr.                 | Butler Student Union  |
| 20              | University of Indianapolis         | 1400 E Hanna Ave.                 | University on the south side of Indianapolis  |
| 21              | 86th & Monon                       | 1410 E 86th St.                   | Nora Shopping Center and Monon access   |
| 22              | Keystone Fashion Mall              | 8680 Keystone Crossing            | Upscale mall on the north side of Indianapolis  |
| 23              | Castleton Mall                     | 6020 E 82nd St.                   | Castleton Square Mall   |
| 24              | Glendale Town Center               | 6101 N Keystone Ave.              | Glendale town center  |
| 25              | Convention Center & Victory Field  | 460 W Maryland St.                | Downtown  |

2015 SEP 10 PM 4 55

**EXHIBIT B**  
**SUBSEQUENT PHASE LOCATIONS**

**Locations 26 to 70**

| <b>Name</b>                       | <b>Address</b>         | <b>Areas/Key Features of Service</b>   |
|-----------------------------------|------------------------|--|
| Central Library                   | 60 E St. Clair St.     | Northside of downtown  |
| Trader's Point Shopping Center    | 6010 W 86th St.        | Shops and restaurants on the City's NW side  |
| Dow Agrosience                    | 9330 Zionsville Rd.    |  |
| Park 100 1                        | 7601 Interactive Way   |  |
| St. Vincent Hospital              | 2001 W 86th St.        |  |
| IU North Hospital                 | 11700 N Meridian St.   |  |
| Community North                   | 7150 Clearvista Dr.    |  |
| Roche Diagnostics                 | 9115 Hague Rd.         |  |
| Fort Ben                          | 9001 E 59th St.        |  |
| Community East Hospital           | 1500 N Ritter Ave.     |  |
| Holliday Park                     | 6363 Spring Mill Rd.   |  |
| Broad Ripple 2                    | 920 Broad Ripple Ave.  |  |
| SoBro 2                           | 5160 N College.        |  |
| SoBro 3                           | 5600 N Illinois St.    |  |
| SoBro 4                           | 4960 N Penn St.        |  |
| Indianapolis Museum of Art        | 4000 Michigan Road.    |  |
| Methodist Hospital                | 1701 N Senate Ave.     |  |
| Eagle Creek Park                  | 7800 Eagle Beach Dr.   | Large park on the City's West side   |
| Indianapolis Motor Speedway       | 4790 W 16th St.        |  |
| Garfield Park                     | 2345 Pagoda Dr.        |  |
| Franciscan St. Francis Health     | 8111 S Emerson Ave.    |  |
| Community South Hospital          | 1402 E County Line Rd. |  |
| Washington & Penn.                | 10 N Pennsylvania St.  |  |
| New York & Capitol                | 140 W New York St.     |  |
| Meridian & South                  | 130 W South St.        |  |
| Banker's Life Fieldhouse          | 180 S Pennsylvania St. | Downtown   |
| Mass Ave 1                        | 300 Mass Ave.          |  |
| Mass Ave 3                        | 710 Mass Ave.          |  |
| Riley Towers                      | 650 N Alabama St.      |  |
| Angie's List                      | 1030 E Washington St.  | Potential corporate client identified.   |
| Statehouse West                   | 480 W Ohio St.         |  |
| Indianapolis Zoo                  | 1200 W Washington St.  |  |
| Cosmopolitan                      | 510 N Senate Ave.      |  |
| War Memorial                      | 310 N Meridian.        |  |
| IUPUI - Bloch Park                | 1000 University Blvd.  |  |
| War Memorial Plaza                | 575 N Pennsylvania St  |  |
| Maryland & Meridian               | 10 W Maryland St.      |  |
| NIFS & Indianapolis Sports Center | 140 Blake St.          |  |
| University Hospital               | 550 University Blvd.   | IU School of Medicine on IUPUI campus  |
| 16 Tech                           | 1300 Waterway Blvd.    | Developing bio-tech campus just North of IUPUI   |
| 16th & Delaware                   | 100 E 16th St.         | A neighborhood, several large apartment buildings, and stores within walking distance of this intersection |
| 25th & Delaware                   | 2447 N Delaware St.    | Shops and neighborhoods in this area   |
| South Meridian                    | 920 S Meridian St.     |  |
| East Ohio                         | 540 E Ohio St.         |  |

### Locations 71 to 200

For Locations 71 to 200, a precise street address has not been defined at this stage. It will be defined over the next few months with input from the City and IPL. The following table shows the anticipated distribution of sites per neighborhood.

| #  | Area   | Approximate Number of Sites |
|----|--|-----------------------------|
| 1  | Greater Downtown                               | 40                          |
| 2  | Broad Ripple                                   | 5                           |
| 3  | Fountain Square                                | 3                           |
| 4  | Irvington                                      | 3                           |
| 5  | Keystone & Castleton                           | 5                           |
| 6  | Trader's Point & Michigan Rd. Shopping Centers | 3                           |
| 7  | Monon Trail                                    | 5                           |
| 8  | Wayne Township                                 | 10                          |
| 9  | Center Township                                | 40                          |
| 10 | Pike Township                                  | 15                          |
| 12 | Washington Township                            | 15                          |
| 13 | Lawrence Township                              | 15                          |
| 14 | Meridian Kessler                               | 5                           |
| 15 | Warren Township                                | 9                           |
| 16 | Franklin Township                              | 9                           |
| 17 | Perry Township                                 | 9                           |
| 18 | Decatur Township                               | 9                           |

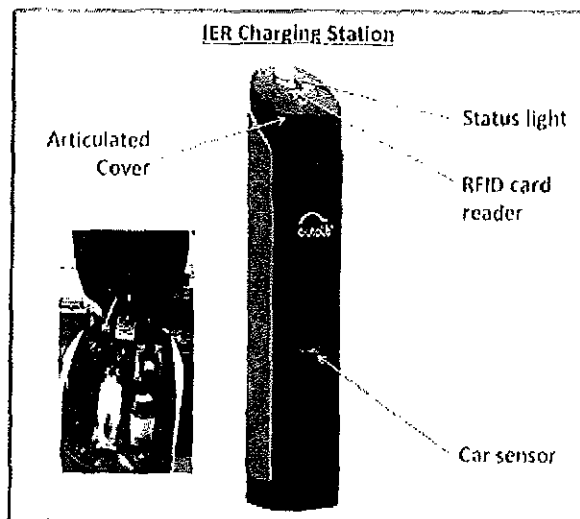

**EXHIBIT C**  
**INSTALLATION REQUIREMENTS**

**1) Equipment to connect**

The following equipment will be supplied by the Company at each Location:

- a. Charging Stations (IER 981E)**
  - o Typically 5 per Location.
  - o The Charging Stations are Level 2: 208/240V, 16A.
  - o Power consumption: up to 4 kW including EV charging.
  - o Total estimated quantity: up to 1,000.



- b. Rental Kiosks (IER 980E)**
  - o Typically 1 per Location.
  - o Total estimated quantity: up to 200
  - o Power consumption: 4kW.

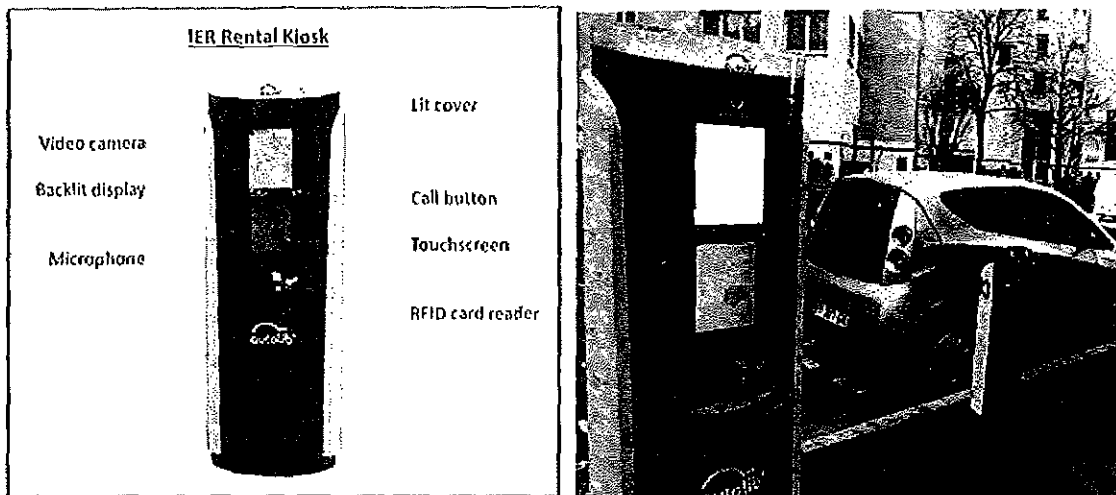

**c. Enrollment Kiosks (IER 983E)**

- Total estimated quantity: 1 per Location, at select Locations only, up to 20 total.
- Power consumption: up to 1,400W including its internal heating elements and the lighting for its shelter. Up to 1,300W without shelter.
- These kiosks will be installed at locations which may or may not be adjacent to car sharing sites.
- Some Enrollment Kiosks will be installed outdoors and housed in “Bubble” shelters provided by the Company or other shelter provided by the City and acceptable to the Company.
- Some will be installed indoors in selected public buildings.

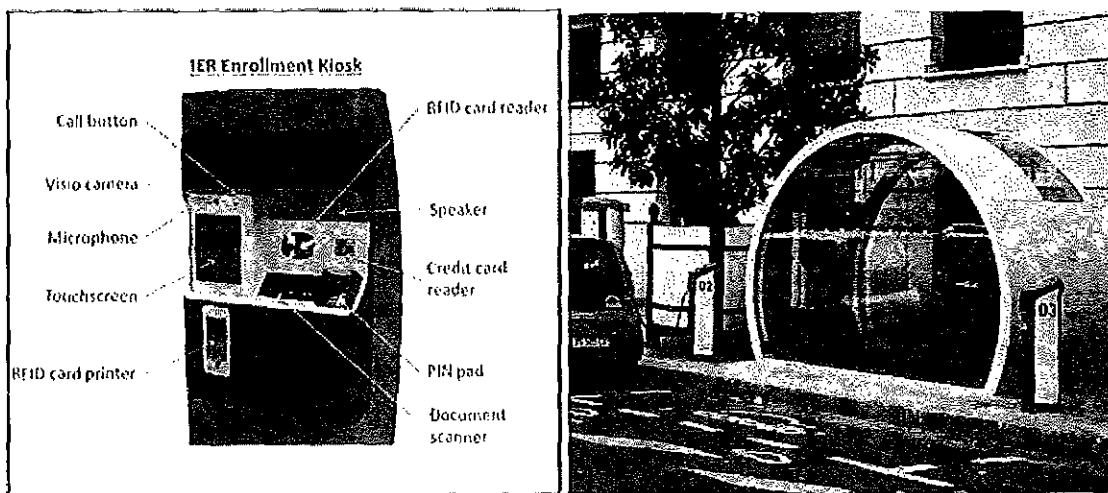

**d. Site configuration**

Prior to installation, the Company will define the configuration of each site:

- Number of Enrollment Kiosks (EK) and Bubble Shelter
- Number of Rental Kiosks (RK)
- Number of Charging Stations (CS)
- Other configuration
- Traffic direction: left or right side of the street if in one-way street

|  |                    |  |
|--|--------------------|--|
| <input type="checkbox"/> Type 1                            | 1 EK + 1 RK + 4 CS |  |
| <input type="checkbox"/> Type 2                            | 1 EK + 1 RK + 5 CS |  |
| <input type="checkbox"/> Type 3                            | 1 EK + 1 RK + 6 CS |  |
| <input type="checkbox"/> Type 4                            | 1 RK + 4 CS        |  |
| <input type="checkbox"/> Type 5                            | 1 RK + 5 CS        |  |
| <input type="checkbox"/> Type 6                            | 1 RK + 6 CS        |  |
| <input type="checkbox"/> Other – Specify number of kiosks: |                    |  |
| EK :   | RK :               | CS :   |
| <input type="checkbox"/> Right side of street              |                    | <input type="checkbox"/> Left side of street |

**2) Electrical connectivity**

IPL shall perform the services described in the Exhibit I to provide electrical connectivity terminated with a meter at the Meter Location determined by IPL within the Perimeter after reviewing the Company's proposed Meter Location and Perimeter identified in each Notice to Proceed, in compliance with the following requirements.

- a. IPL will provide 120/208 Volt, 4-wire service at all Locations, based on the planned 200 A, 3 phase service.
- b. 3 phase service in WYE configuration with Neutral:

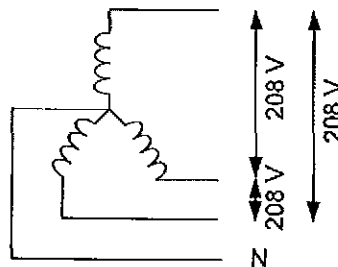

- c. A typical car sharing site will draw 24 kW with one Rental Kiosk and 5 Charging Stations charging 5 EVs at the maximum output of the Charging Stations.
- d. Some sites may have more Charging Stations (such as the Airport or the Convention Center). For such site, a specific sizing study of the electrical supply will be done by the Company based on the number of Kiosks and Charging stations decided by the Company. The result of the sizing study shall be included in the Notice to Proceed.

- e. All components and service installed by IPL will be rated to operate in outdoor conditions in Indianapolis.
- f. The Company will provide a grounding cable for each Meter Location, 1 grounding rod per location, with grounding cable 1m long above ground, 25mm diameter or applicable standard.
- g. US standard measurement equivalents may be substituted for any dimensions given in metric standards.

The Company will install the following electrical distribution:

- a. The Company will install for each Charging Station a 20A breaker.
- b. At a car sharing site, the electric supply will be a single feed to the base of the Rental Kiosk, with local distribution cables from the Rental Kiosk to the Charging Stations, as shown in the following diagram:

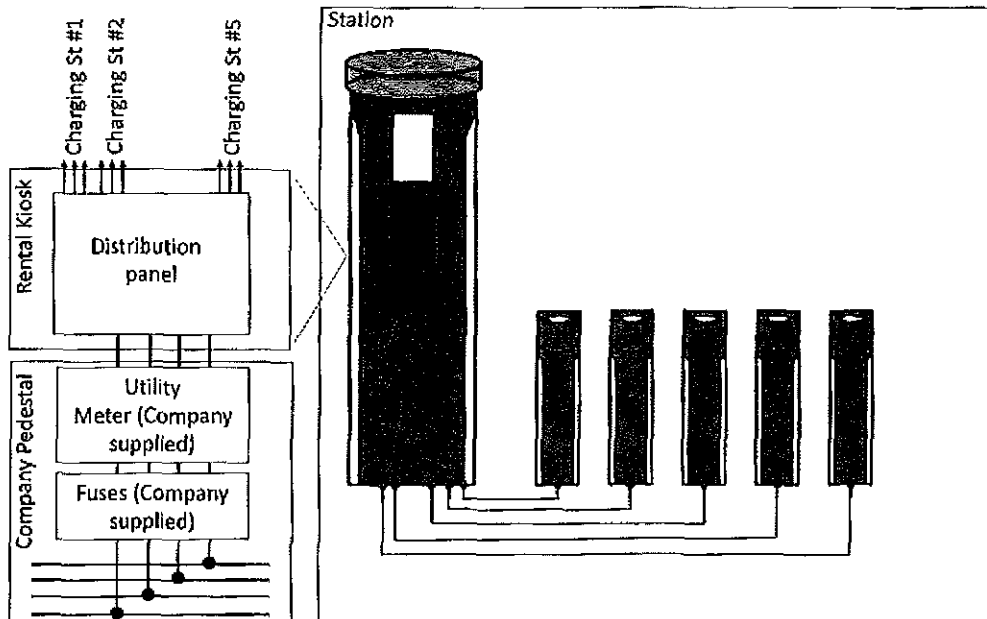

- c. If an Enrollment Kiosk is installed at a car sharing site, it is also fed from the Rental Kiosk.
- d. The distribution cables will be installed in a WYE configuration (parallel) between the Rental Kiosk and the Charging Stations and optional Enrollment Kiosk.
- e. There will be a master fuse and/or circuit breaker and electric meter housed in a Meter Pedestal cabinet separate from any Kiosk for each electric feed. The Company provided the specification and size of these components in Exhibit D typical drawings A (CBD) and B (non-CBD) which are acceptable to IPL for standard 200 amp site described in 2 a above. . See Exhibit D for a representative drawing of the meter pedestal cabinet.

### 3) Network access

- a. High speed network access needs to be provided to each Rental Kiosk and each Enrollment Kiosk. The Company will select the Network Providers best able to meet the requirements of the service. There will likely be multiple providers to cover all the sites and these may include BrightHouse, AT&T, Comcast or others. Network access may be fiber optic, coax cable or copper cable. For each site, the Company will inform IPL of the selected Network Provider.
- b. The City will coordinate work with the Network Provider to minimize exposure of the public to open trenches based on advance notice time to be agreed between IPL and the Network Provider.
- c. The Company or the City will communicate with the Network Provider regarding the installation schedule set out in a Notice to Proceed. The City shall coordinate such installation at each Location to help ensure that installation of communications and electricity is performed at or near the same time in order to avoid any additional digging/filling of pavement and roads.
- d. The Company or its subcontractor will provide and install the conduit between the Network Provider designated connection box and the Rental Kiosk or Enrollment Kiosk:
  - a. Two 2-inch diameter conduits are requested between the Network Provider connection box and the Rental Kiosk or Enrollment Kiosk.
  - b. 8 feet of network cable length must be reserved at the Kiosk side.
- e. Subject to the Network Provider's specification and so long as also agreed by the Engineer of Record, it is recommended that the conduit be encased in concrete for 6ft at the connection box.
- f. The Company or its subcontractor will inform the Network Provider when conduits are available for cable installation and connection test.
- g. Subject to Section 3(h), the Company will ensure that network conduits are encased in the concrete bases as described in Section 5 below.
- h. For non-CBD network Locations, IPL will allow the Company's network provider to install network cable in the IPL trench subject to Section (f)(iii) of Exhibit I.

#### 4) Cabling Requirements

The table below shows the different conduits and cables to be provided by the Company. The Company will provide updated dimensions, specifications and a typical cabling final drawing.

| Origin / Destination            | Description          | Conduit Diam. | Cable Specification  | Cable Length  |              | Connector  |  |
|---------------------------------|----------------------|---------------|--|---------------|--------------|--|--|
|                                 |                      |               |  | Inside Origin | Inside Dest. | At Origin  | At Destination   |
| Network Provider / Rental Kiosk | Network              | 2"            | To Be Confirmed  |               | 7'3"         | To Be Confirmed  | To Be Confirmed  |
|                                 | Spare                | 2"            |  |               |              |  |  |
| Network Provider / Rental Kiosk | Power                | 1.25"         | 12AWG SOOW   | 5'7"          | 2'           |  |  |
| Rental Kiosk / Charging Station | Data (RS422)         | 1.25"         | LIYCY-BP 3x2x0.34. 3 pair control cable with individual copper shielding for high electro-magnetic interference environment. | 5'7"          | 2'           | 1881354 (Phoenix Contact) + Sleeve Schneider DZ5-CE003 or equivalent                     | 1881354 (Phoenix Contact) + Sleeve Schneider DZ5-CE003 or equivalent                       |
| Rental Kiosk / Charging Station | Network              | 1.25"         | CAT6a S/FTP AWG 23   | 4'3"          | 1'7"         | Female RJ 45 plug, CAT6 or CAT6a S/FTP, for connection to RJ45 patch cord to DSL switch. | Female RJ 45 plug, CAT6 or CAT6a S/FTP, for connection to RJ45 patch cord to CPL modem.    |
| Rental Kiosk / Enrollment Kiosk | Power (Rental Kiosk) | 1.25"         | 12AWG SOOW   | 5'7"          | 2'           |  |  |
| Rental Kiosk / Enrollment Kiosk | Network (POS)        | 1.25"         | CAT6a S/FTP AWG 23   | 4'3"          | 2'8"         | Female RJ 45 plug, CAT6 or CAT6a S/FTP, for connection to RJ45 patch cord to DSL switch. | Female RJ 45 plug, CAT6 or CAT6a S/FTP, for connection to RJ45 patch cord to Point Of Sale |
| Rental Kiosk / Enrollment Kiosk | Network (PC)         | 1.25"         | CAT6a S/FTP AWG 23   | 4'3"          | 2'8"         | Female RJ 45 plug, CAT6 or CAT6a S/FTP, for connection to RJ45 patch cord to DSL switch. | Female RJ 45 plug, CAT6 or CAT6a S/FTP, for connection to RJ45 patch cord to PC.           |

**5) Equipment Mounting / Concrete Bases**

**a. Concrete base**

Subject to Section 3(h), the Company will install concrete bases and mounting threaded rods for installation of the Kiosks and Charging Stations according to the representative requirements listed below. The Company will finalize the concrete base design based upon Indianapolis weather conditions.

- Rental Kiosk
  - Concrete base 40"x40"x10"
  - M12 threaded anchor rods
- Enrollment Kiosk
  - Concrete base 87"x87"x12"
  - Top 2" under grade
  - M12 threaded anchor rods
- Charging Station
  - Concrete base 24"x24"x20"
  - M12 threaded anchor rods

**b. Mounting requirements**

- i. The ground where the equipment is to be installed must be level and smooth with a maximum slope of 0.5%.
- i. The Kiosks and Charging Stations must be installed on a concrete base sufficient to carry their weight and compliant with applicable standards. The equipment weight is as follows:

| Equipment        | Weight (lbs.) |
|------------------|---------------|
| Enrollment Kiosk | 550           |
| Rental Kiosk     | 441           |
| Charging Station | 177           |

- ii. The threaded rods must protrude 1.97" +0/-0.4" above the base plate.
- iii. The threaded rods must be perpendicular to the concrete base with maximum deviation of 0.5%.
- iv. The Company will provide Mounting Templates for each equipment type allowing verifying the proper dimensions and location of the concrete bases, mounting rods and cable conduits.

**c. Equipment size and clearance**

Below are drawings showing equipment sizes, including sizes with doors open along with the clearances to allow around the equipment for installation and service. Installation should only occur when such clearances are available. All dimensions are in millimeters followed by their inch equivalent.

i. Rental Kiosk - Overall Dimensions (in mm [inches])

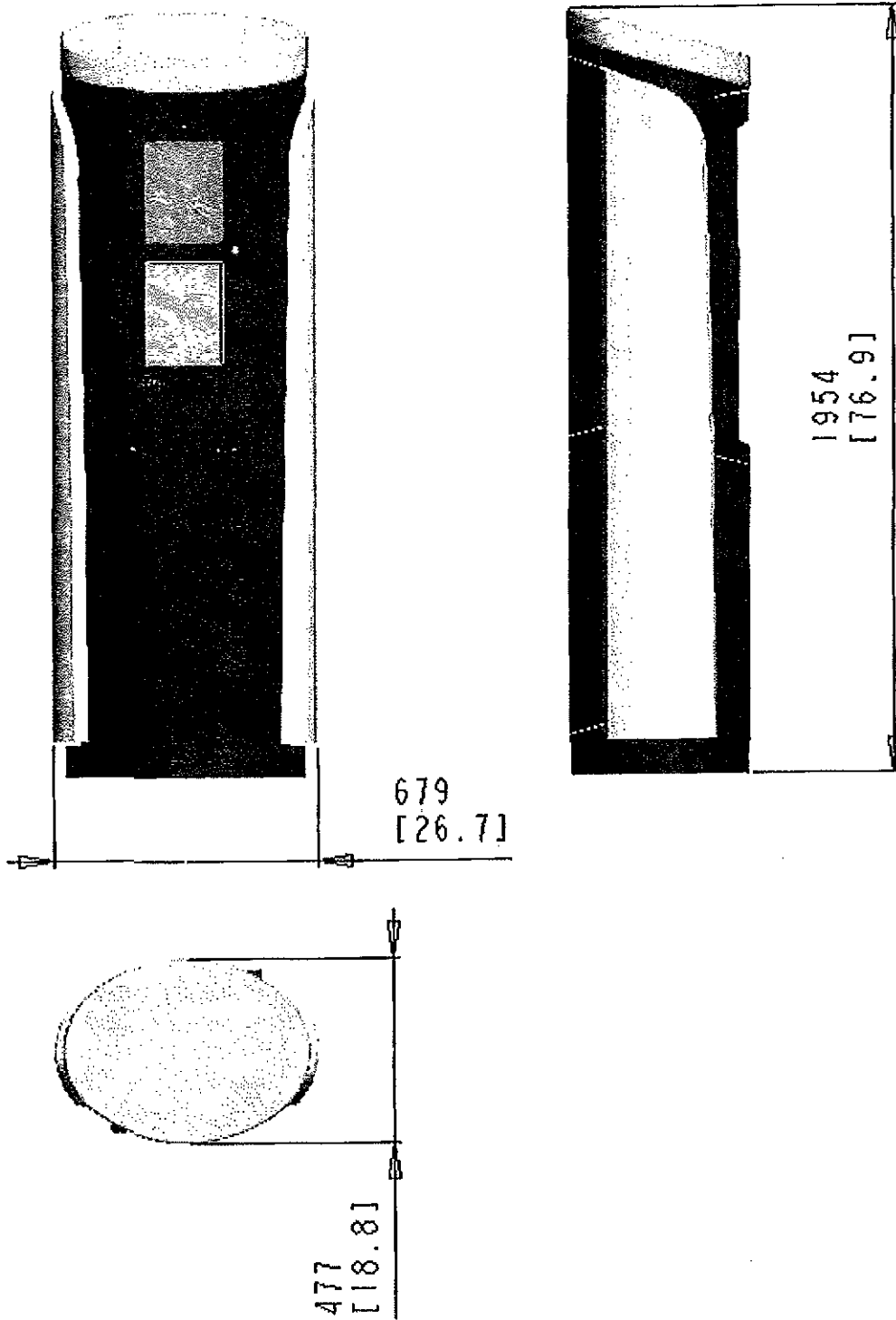



ii. Rental Kiosk - Front and Back Open Dimensions (in mm [inches])

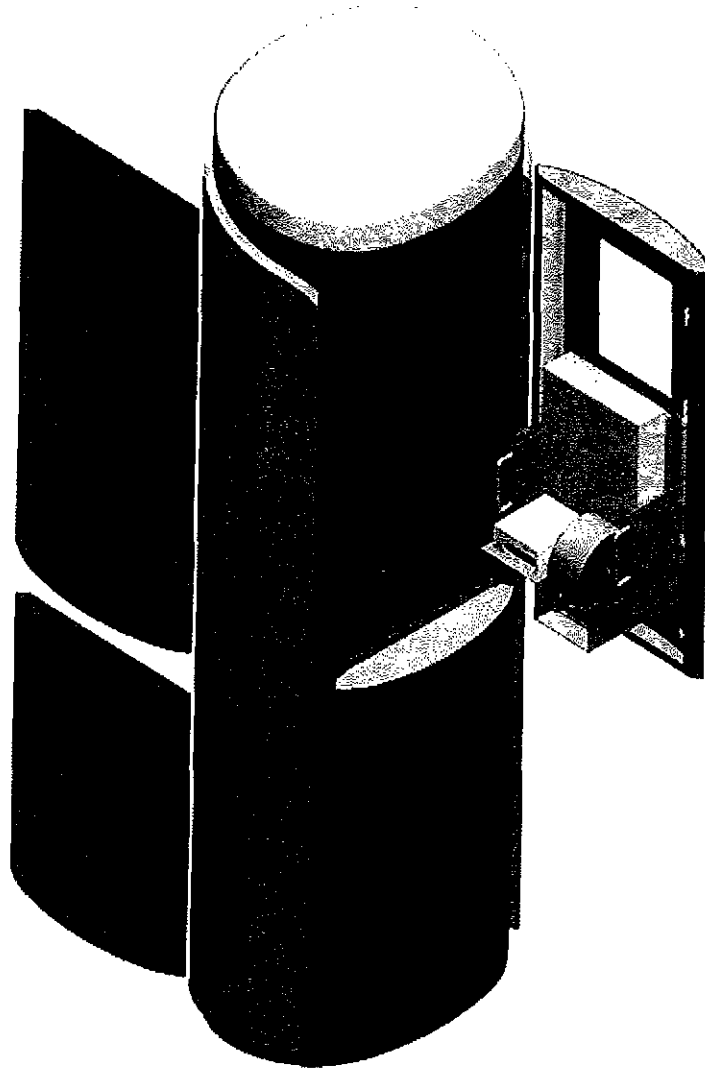

iii. Rental Kiosk - Front Open Dimensions (in mm [inches])

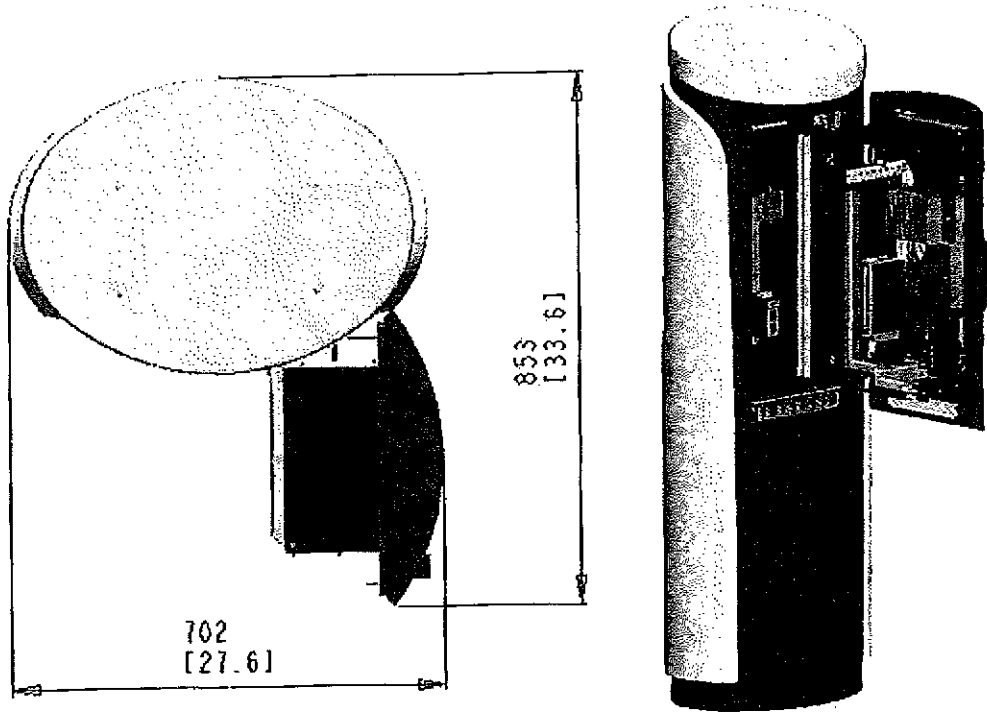

iv. Rental Kiosk - Back Open Dimensions

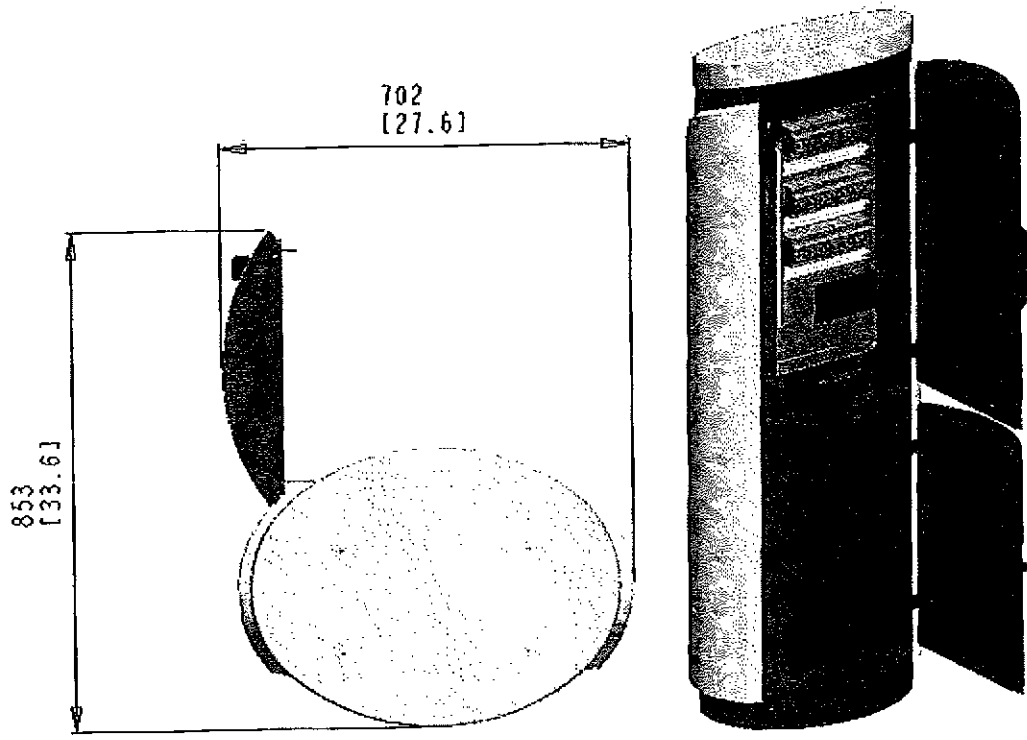

v. Rental Kiosk - Anchoring (in mm [inches])

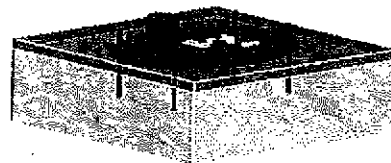
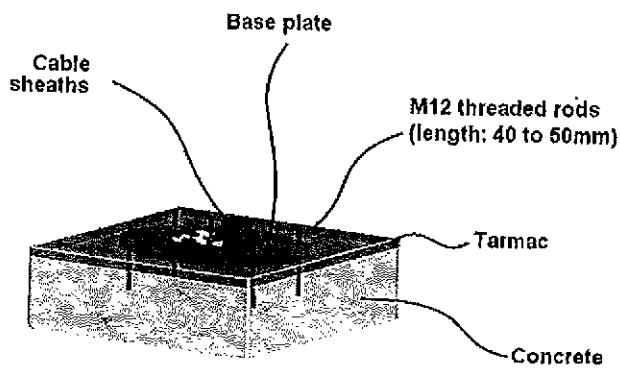
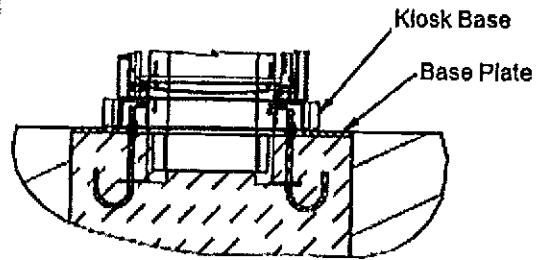
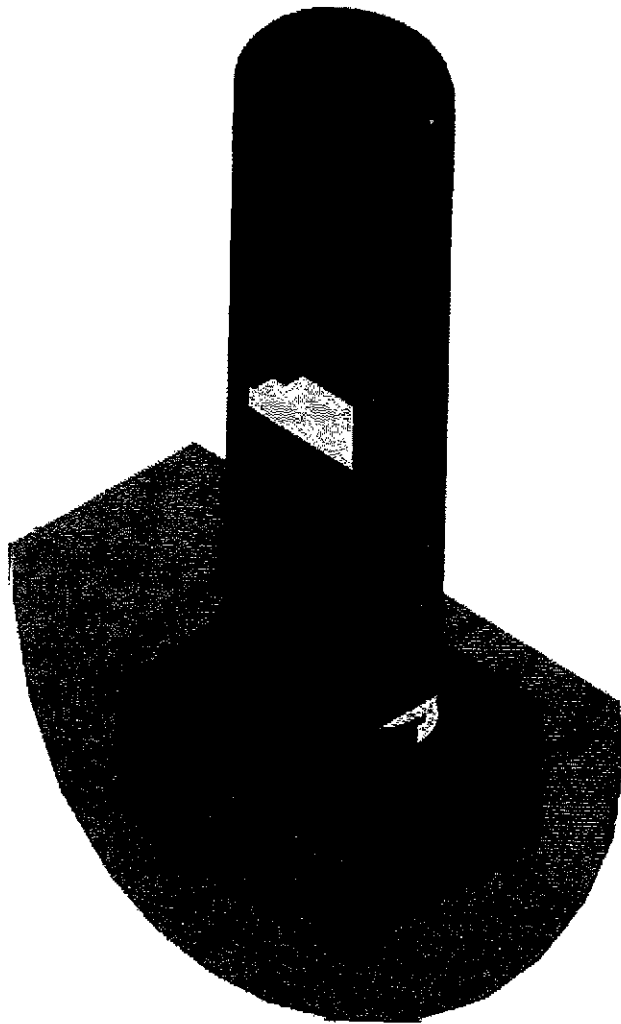

vi. Rental Kiosk - Electric Cabinet Mounting (in mm [inches])

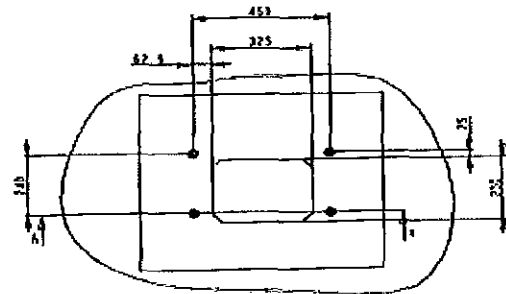
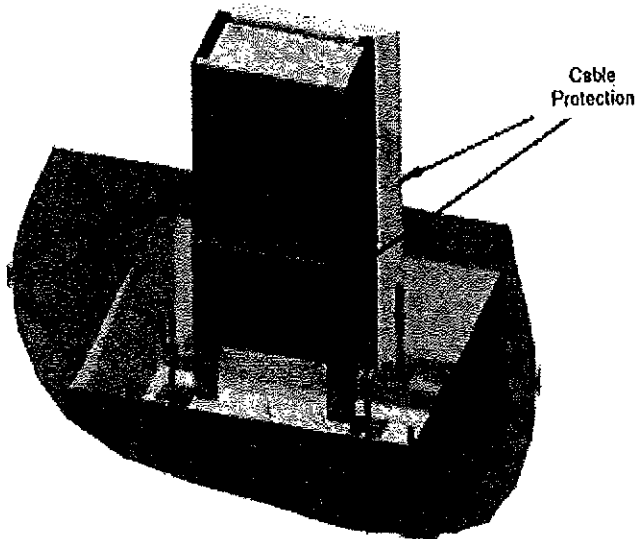
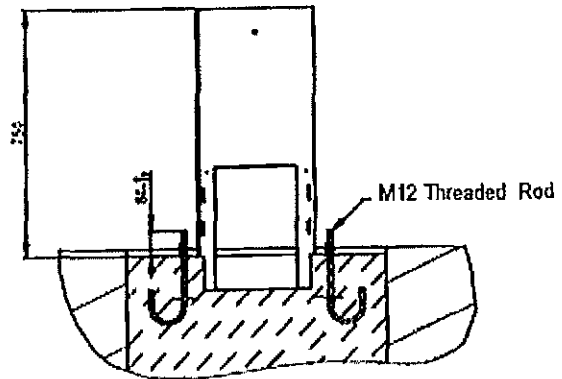
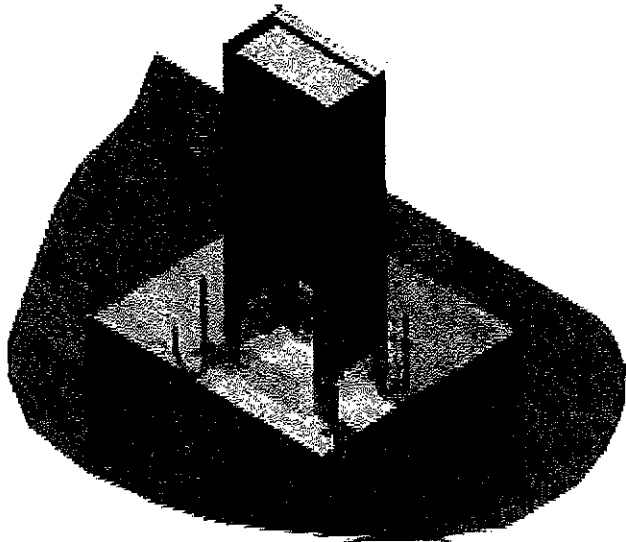



viii. Rental Kiosk – Clearance for Installation and Service (in mm [inches])

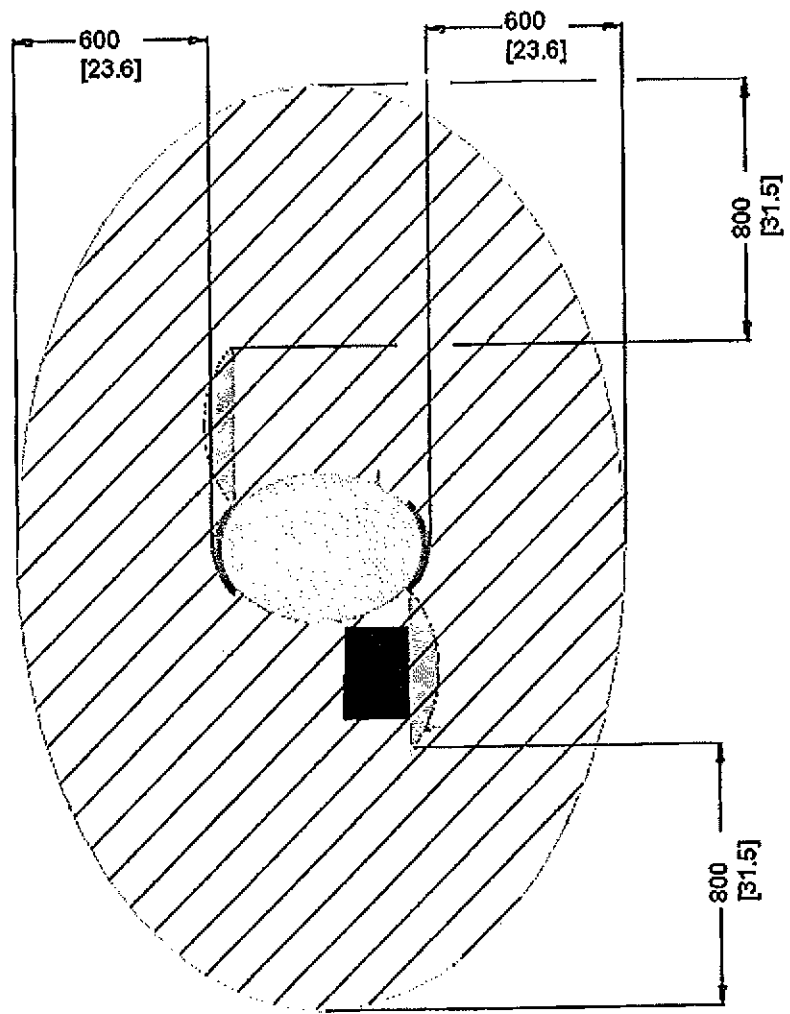

ix. Charging Station – Overall Dimensions (in mm [inches])

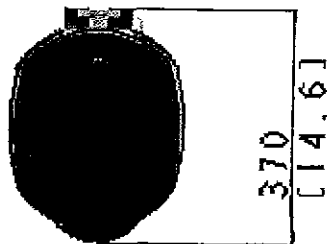
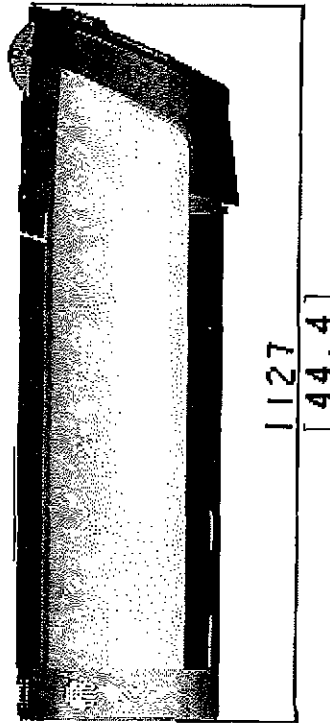

x. Charging Station – Open Dimensions (in mm [inches])

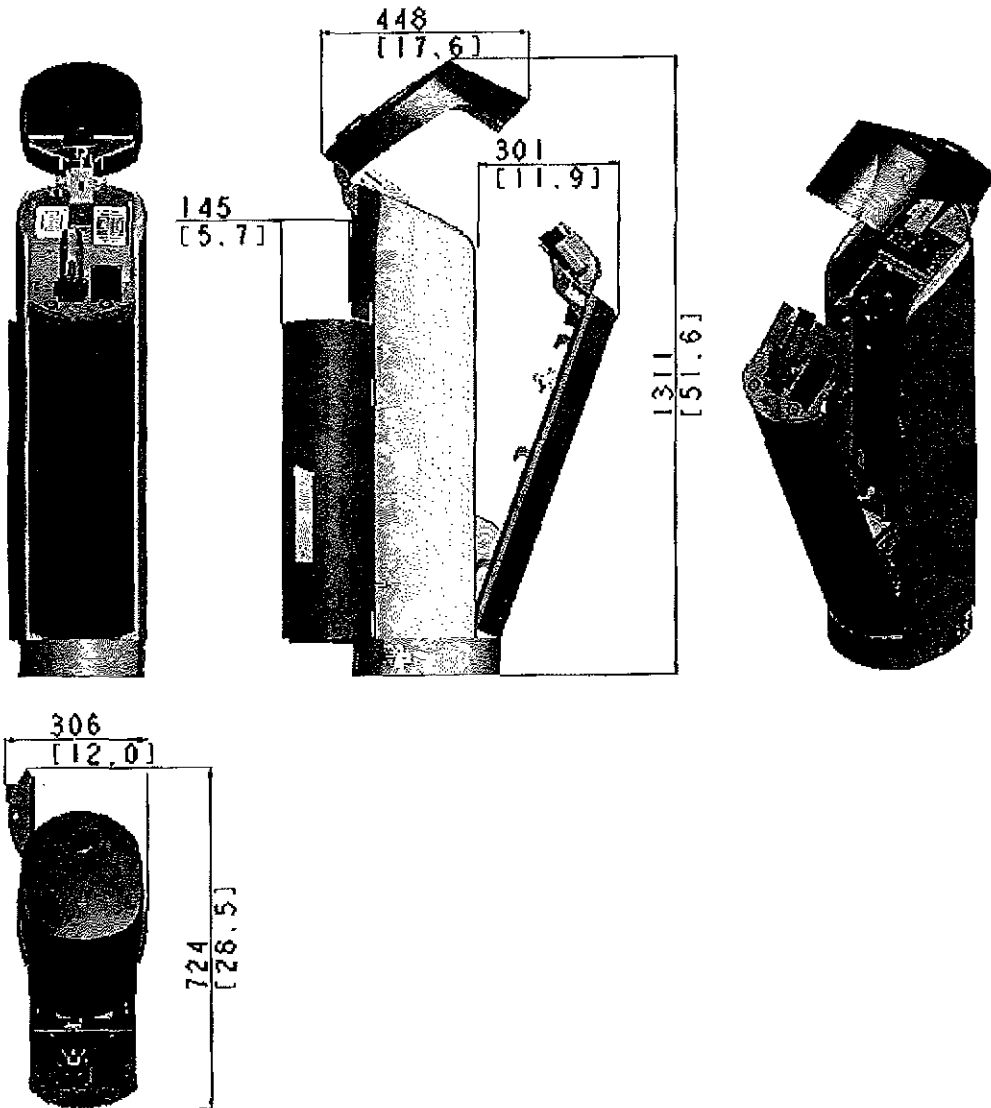



xi. Charging Station – Anchoring (in mm)

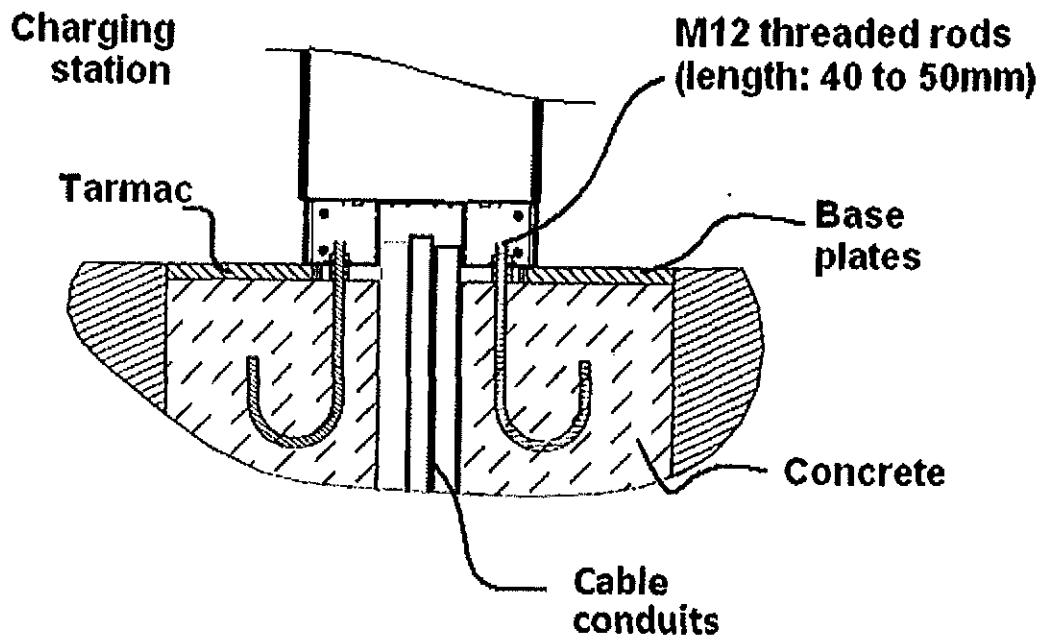
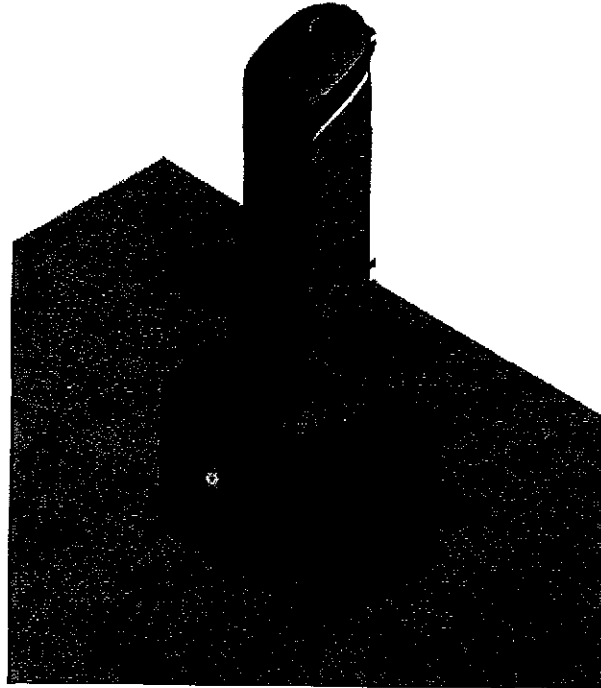

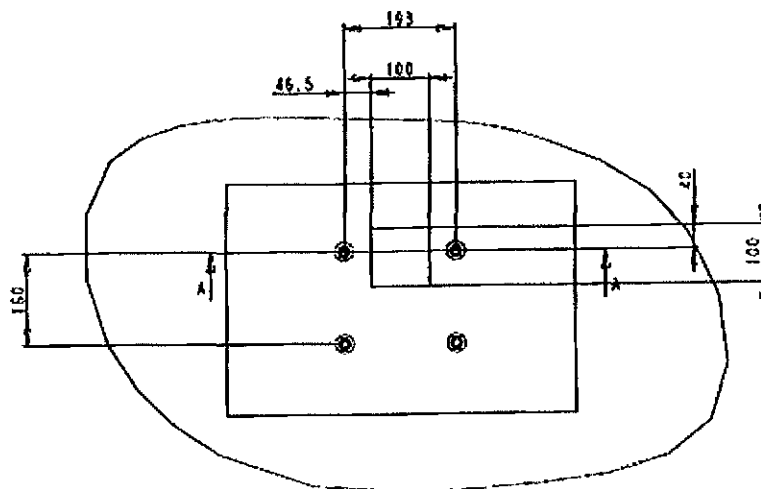
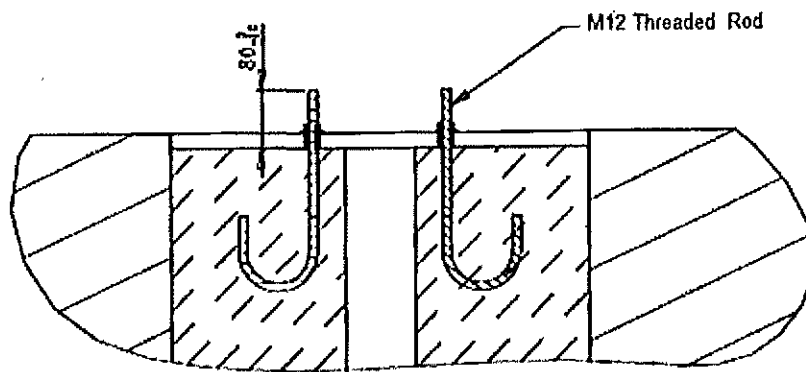
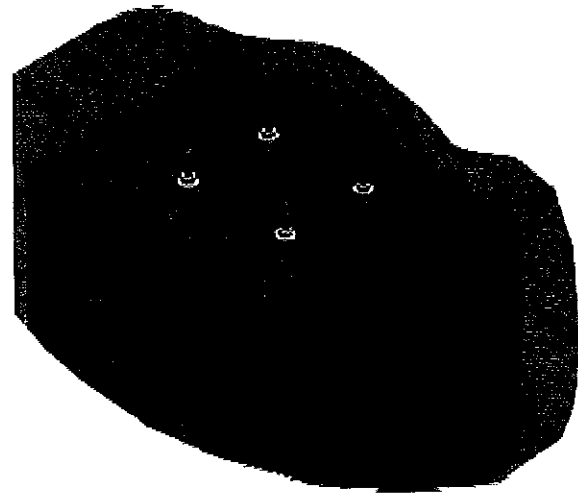

xii. Charging Station – Base Plate (in mm)

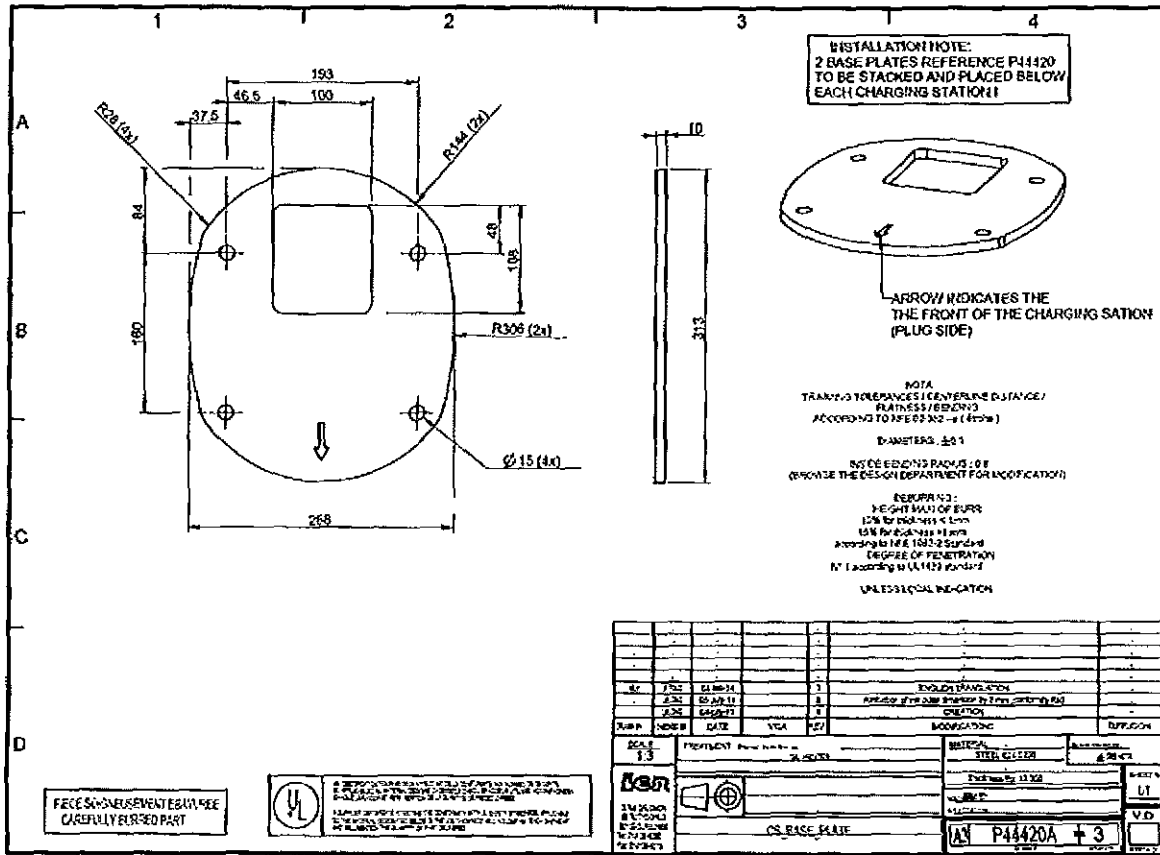

xiii. Charging Station – Clearance for Installation and Service (in mm [inches])

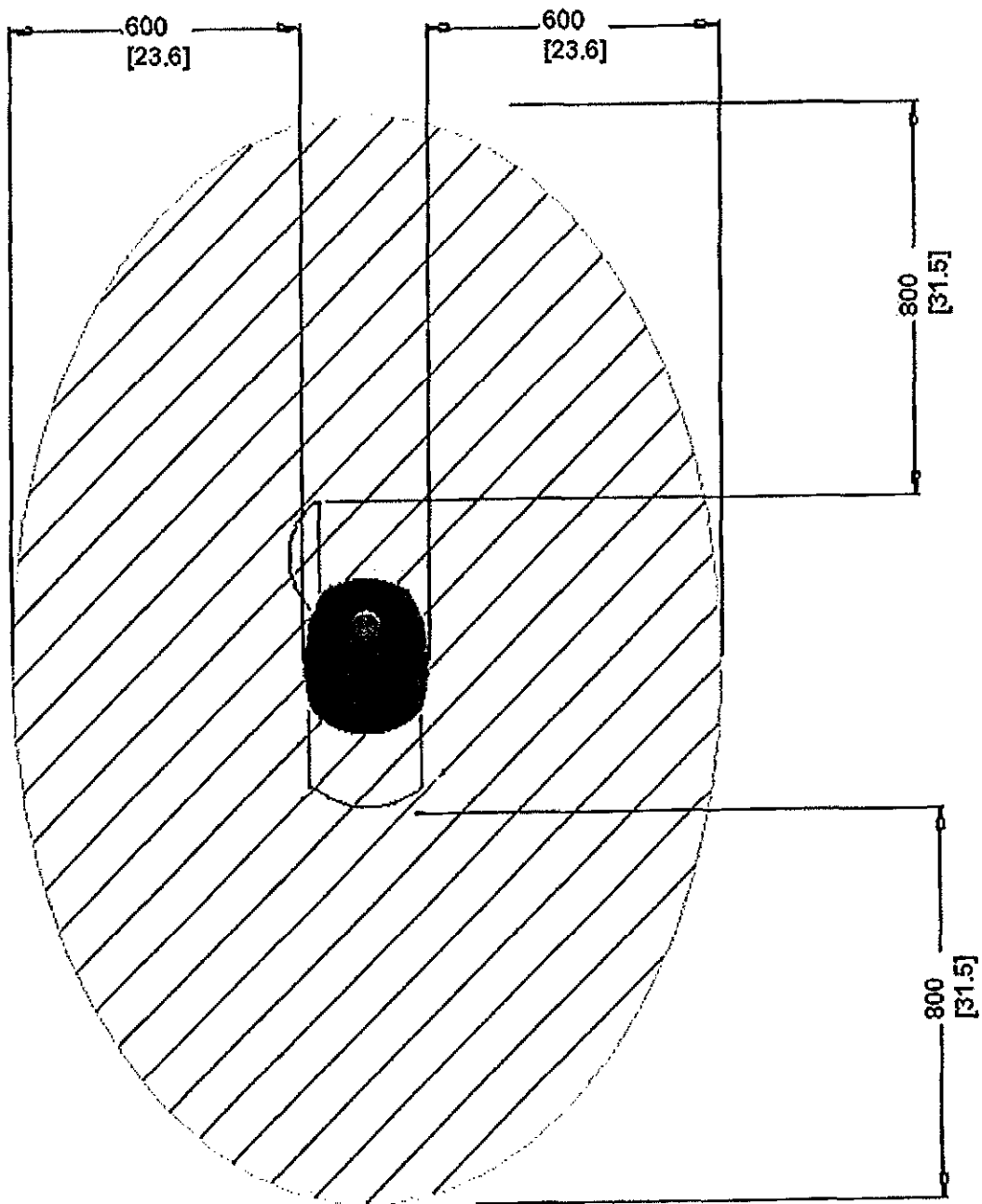

xiv. Enrollment Kiosk – Overall Dimensions (in mm [inches])

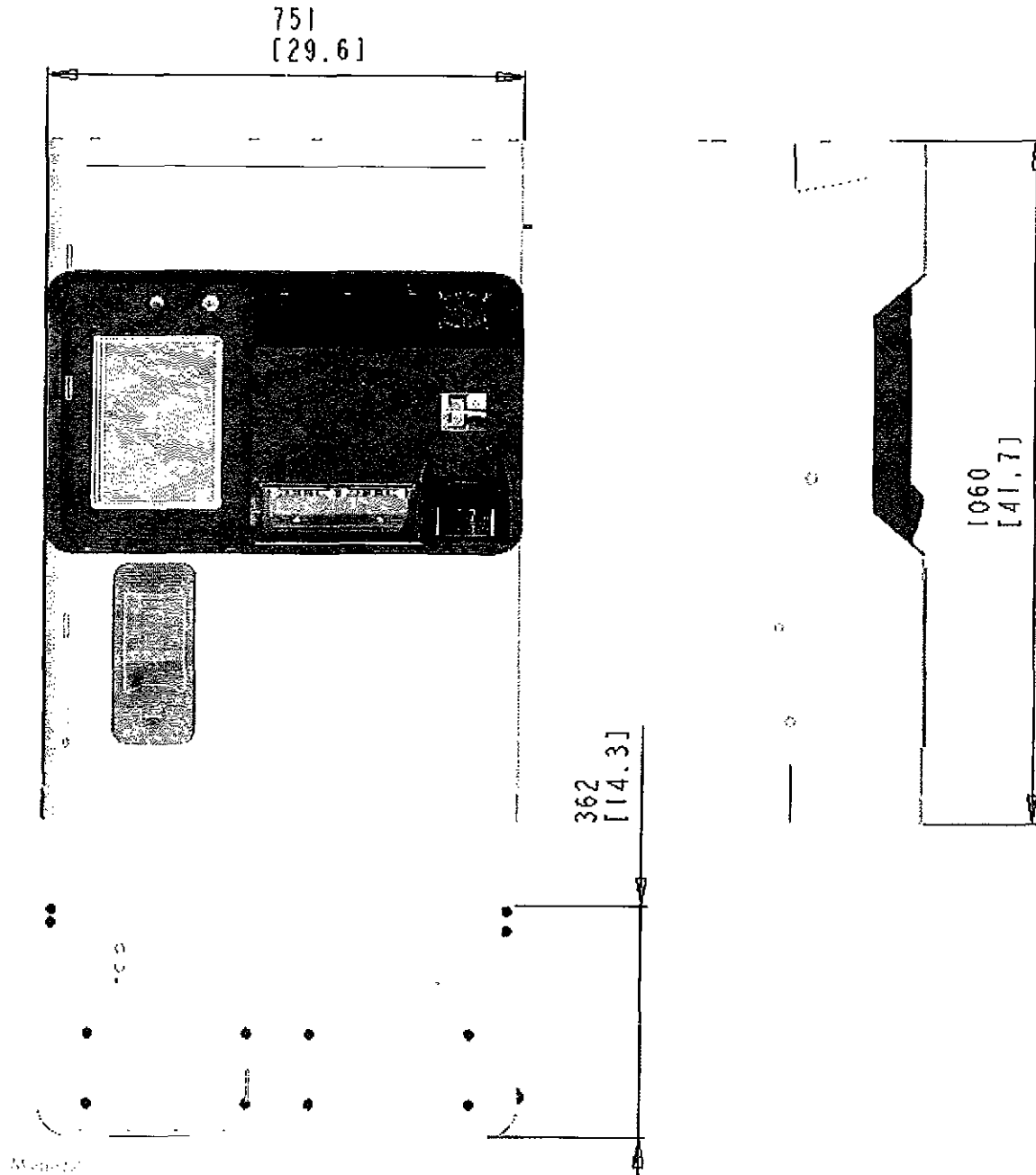

xv. Enrollment Kiosk – Open Dimensions (in mm [inches])

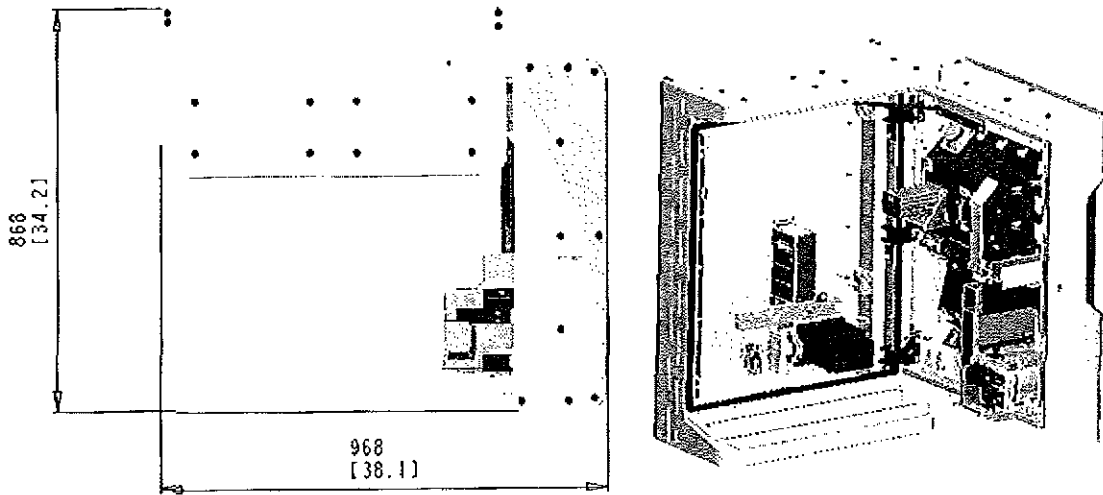

i. Enrollment Kiosk – Floor Mounting

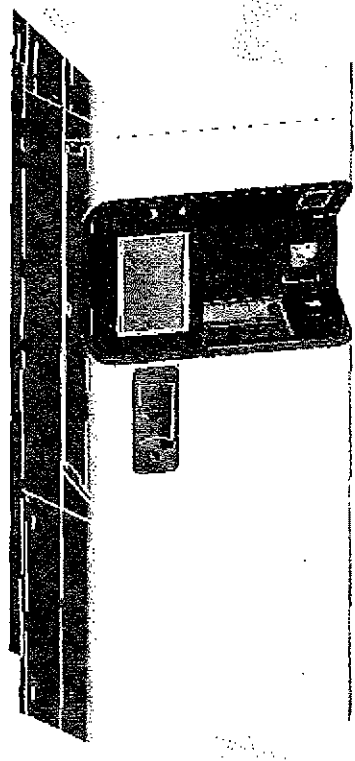

ii. Enrollment Kiosk - Clearance for Installation and Service (in mm [inches])

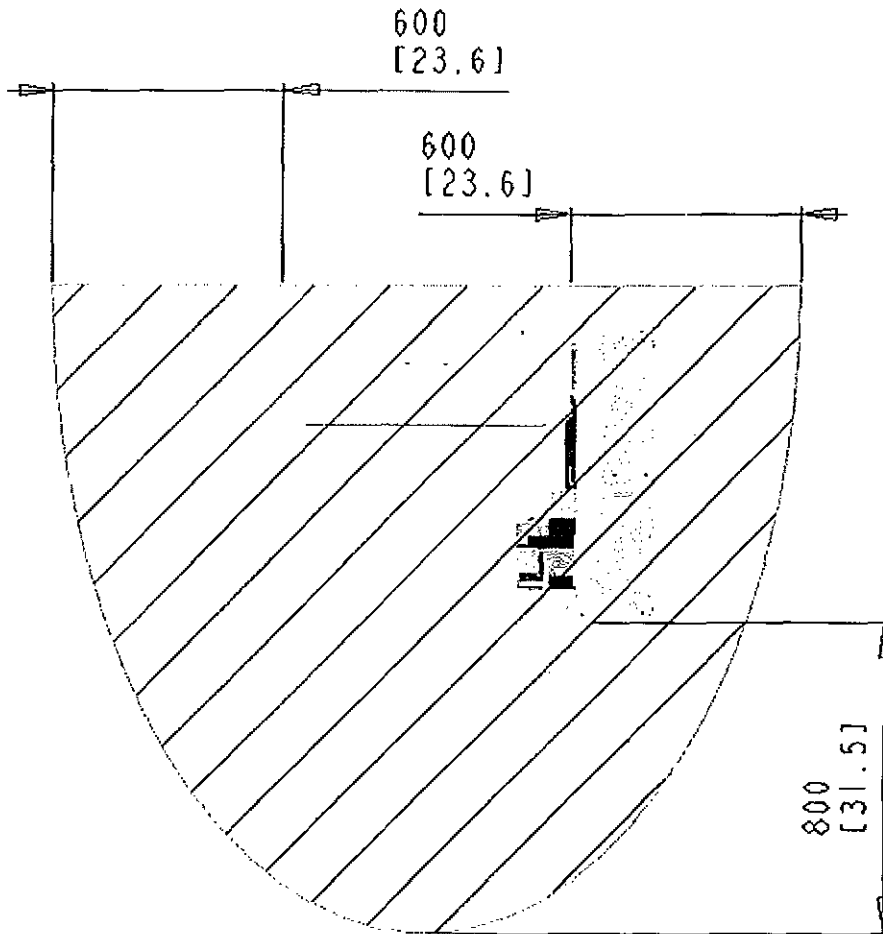

**6) Site Preparation and Installation Completion**

- a. Following receipt of a Notice to Proceed and prior to start of installation work by IPL and by the Company, the City will coordinate a Location assessment with the parties identified in the table in section 8 and the Company's electrical and excavation contractors. The Company will identify any obstacles or debris at the site that must be removed by the property owner or the City before installation will begin.
- b. IPL will perform the service extension in accordance with the Exhibit I.
- c. The Company Contractor will perform the installation of the Location Fixtures supplied by the Company. The Company will be given advance notice and will have the opportunity to observe such installation.

**7) Road Markings and Street Signage**

- a. The City will ensure that street parking spaces are marked as reserved for the car sharing service. This will include road painting to delineate the reserved spots, along with any adequate logo or text to indicate the spaces are reserved for the car sharing service.
- b. The City will install street signs at the car sharing site to:
  - i. Identify the service.
  - ii. Indicate that the reserved spots should only be used by authorized users and that unauthorized users will be towed away at owner's cost.
- c. The proposed markings and signage should be reviewed and approved by the Company.
- d. The markings and signage should comply with any applicable regulation, best practice or industry recommendation related to EVs.



**Typical Street Layout:**

Due to the limited length of the charge cord, the charging stations should be installed as close as possible to the curb (12"), perpendicular to it and in the middle of the parking space. Note that the layout below shows a different configuration.

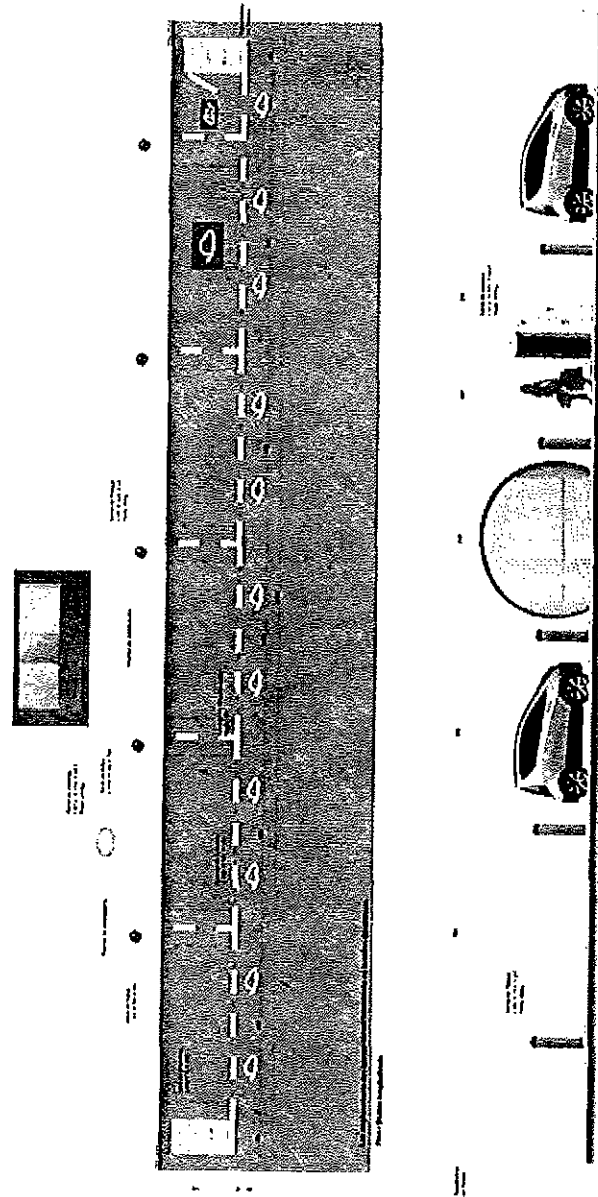

8) **Summary Roles and Responsibilities** – The table below identifies activity participation by the Parties, IPL, and other Persons.

| Task   | Company | City | IPL | Network Provider <sup>1</sup> | Property Owner |
|--|---------|------|-----|-------------------------------|----------------|
| Site selection/Location list   | X       | X    | X   | X                             | X              |
| Site Plan  |         | X    |     |                               |                |
| Issuance of Notice to Proceed  | X       |      |     |                               |                |
| Survey and site assessment   | X       | X    | X   | X                             | X              |
| Acceptance or Rejection of Notice to Proceed   |         | X    |     |                               |                |
| Technical Validation & Map   | X       |      |     | X                             |                |
| Site layout engineering  | X       |      | X   | X                             |                |
| Extension budget   |         |      | X   |                               |                |
| Cost estimates   | X       |      | X   | X                             |                |
| Pricing approval   | X       |      | X   |                               |                |
| Construction authorization for electrical installation                                 | X       |      |     |                               | X              |
| Construction authorization for electrical extension                                    | X       |      | X   |                               | X              |
| Construction authorization for network installation                                    | X       |      |     |                               | X              |
| Permitting—IPL's Work  |         |      | X   |                               |                |
| Permitting—other City's Work   | X       | X    |     |                               |                |
| Telecom order  | X       |      |     | X                             |                |
| Utility power order  |         |      | X   |                               |                |
| Utility locates & surveying  | X       |      | X   |                               |                |
| Site Cabling   | X       |      |     | X                             |                |
| Mobilization/security control  | X       |      |     |                               |                |
| Site preparation and demolition for installation work                                  | X       |      |     |                               |                |
| Site preparation for extension service (Non-CBD)                                       |         |      | X   |                               |                |
| Underground conduit rough in service (non-CBD)   |         |      | X   |                               |                |
| Underground conduit rough in service (CBD)   | X       |      |     |                               |                |
| Underground conduit rough in service (from pedestal to Location Fixtures)              | X       |      |     |                               |                |
| Equipment concrete base installation   | X       |      |     |                               |                |
| Site restoration, sidewalks, street and ground repair (non-CBD) <sup>2</sup>           |         |      | X   | X                             |                |
| Site restoration, sidewalks, street and ground repair (CBD)                            | X       |      |     | X                             |                |
| Site restoration, sidewalks, street and ground repair (Location Fixtures) <sup>3</sup> | X       |      |     | X                             |                |
| Kiosk Installation (outdoor)   | X       |      |     |                               |                |
| Kiosk Installation (indoor)  | X       |      |     |                               |                |
| Charging Stations Installation   | X       |      |     |                               |                |

<sup>1</sup> Network Provider will assume all responsibilities for the Location associated with underground work, including any site restoration, sidewalks, street and ground repair made necessary in the event its network installation work continues after IPL has closed IPL's trench.

<sup>2</sup> Based on joint trench agreements

<sup>3</sup> Based on joint trench agreements

| Task  | Company | City | IPL | Network Provider <sup>1</sup> | Property Owner |
|---|---------|------|-----|-------------------------------|----------------|
| Utility electric service installation   |         |      | X   |                               |                |
| Telecom network provisioning  |         |      |     | X                             |                |
| Electrical inspection   | X       |      |     |                               |                |
| Energize electric utility service   |         |      | X   |                               |                |
| Kiosk and charger wiring  | X       |      |     |                               |                |
| Network connection validation   |         |      |     | X                             |                |
| Energizing rental kiosk and chargers  | X       |      |     |                               |                |
| Commission, testing and checkout  | X       |      |     |                               |                |
| Traffic control removal and final site clean up                                   | X       |      |     |                               |                |
| Traffic control for IPL trench work and clean up IPL portion of the site (if any) |         |      | X   |                               |                |
| Equipment Commissioning   | X       |      |     |                               |                |
| Installation Acceptance   | X       | X    |     |                               |                |
| Road marking, signage   |         | X    |     |                               |                |
| Commencement of Commercial Operation  | X       |      |     |                               |                |

INDS01 1502784v10

EXHIBIT D  
TECHNICAL DESCRIPTION OF KIOSKS

IER, Time Saver



IER 980

SELF-SERVICE RENTAL KIOSK FOR QUICK ACCESS TO A CAR SHARING SERVICE OR AN ELECTRIC CAR CHARGING STATION

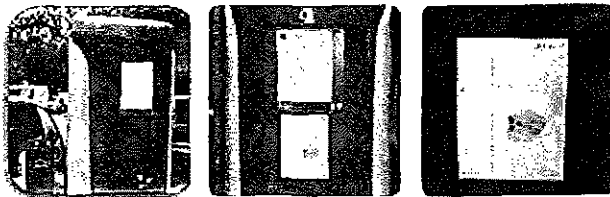

## IER 980 BENEFITS

- Service available 24 hours a day, 7 days a week
- Easy connection to the call center
- Touchscreen
- Backlit static display for street information
- Call button for Helpdesk access
- Speaker/Microphone
- Designed for operation in an urban environment
- Part of the "Ready To Share" offer from IER
- Management capability of 6 EV charging station
- Administration and remote monitoring
- Lighted kiosk top visible from a distance
- Installation in outdoor environment
- Multi-language user interface
- 3 secured access points to simplify maintenance
- Anti-graffiti coating
- Video camera available for surveillance
- Hidden lock

## DESCRIPTION

The IER 980 kiosk allows easy and rapid access to a car-sharing service or an EV charging station. Designed for installation in an urban environment, the kiosk is easily located by users, day and night. It allows users to identify themselves, confirm the desired vehicle or interact with the call center.

In an EV environment, the self-service Rental Kiosk is also able to manage up to 6 IER 981 EV charging stations (control and electrical distribution).

As part of the "Ready To Share" infrastructure, the IER 980 kiosk can be managed remotely along with assistance for pro-active maintenance, remote intervention, administration and maintenance.

## PRODUCT SPECIFICATIONS

|                         |  |
|-------------------------|--|
| Touchscreen             | 12.1 inch flat TFT, wide angle, LCD color display  |
| Resolution              | XGA 768 x 1024 pixels (vertical)   |
| Touchscreen             | PCT - projected capacitive   |
| PC                      | Industrial PC (no moving parts: without air fan, SATA flash SSD),<br>Windows POSReady or 7 |
| Audio conference system | Intel Atom D525 Dual Core processor, 1.8GHz  |
| Surveillance camera     | Noise optimization system, waterproof microphones  |
| RFID reader             | 640 x 480 pixels resolution  |
| Connectivity            | ISO 14443 A/B compliant cards, MiFare, DESfire and Calypso                                 |
| Physical protection     | RJ45 plug for modem GSM 3G+ ADSL 2+  |
| Dimensions              | IP54 tested, anti-graffiti coating, sheet steel 2 mm                                       |
| Weight                  | W 26.6" x D 18.3" x H 76.8"<br>441 lbs.  |

IER, Time Saver



IER 981

ELECTRIC VEHICLE CHARGING STATION FOR STREET INSTALLATION

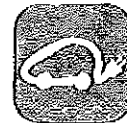
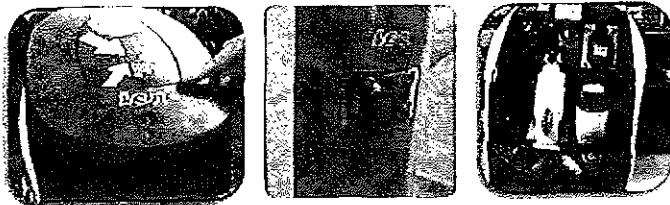

## IER 981 BENEFITS

- Ruggedized for street installation (rustproof and damage proof)
- Solution fit for paid-access areas
- Part of IER's "Ready To Share" solution
- Extremely robust and proven solution
- Easy to use
- Anti-graffiti coating
- User-friendly and secure contactless solution for identification and access
- Management and remote monitoring
- Up to 3 connections
- Integrated retractable cord
- Vehicle radar detection
- Communicate with EV through CPL

## DESCRIPTION

The IER 981 Charging Station has been specifically designed for the convenience of EV owners in an urban environment. It is specially adapted for difficult outdoor environments (rustproof, damage proof) and for intensive use. Depending on its environment, access to the Charging Station can be controlled and secure. An optional contactless interface is available for user identification. An indicator light on the casing can be configured to show its status (for example: parking booked, free vehicle, out of order). The IER 981 can be controlled remotely via a fixed or wireless Ethernet connection with 3G modem. The IER 981 Charging Station is available in 2 versions: a connected autonomous version which can be installed without particular restrictions and a cluster version, whereby several Charging Stations can be managed by an IER 980 Rental Kiosk to offer up to 6 charging points.

## PRODUCT SPECIFICATIONS

|                                      |   |
|--------------------------------------|---|
| Installation                         | Charging station designed for outside installation  |
| Control interface                    | Led display - 3 colors: green: kiosk available / blue: booked, charging / red: issue  |
| Identification by contactless reader | Reader ISO 14443 A/B, MiFare, DESfire and Calypso<br>Reading distance: 4 cm on MiFare ultraLight<br>Support of SAM included for cryptographic function  |
| Type of charge                       | Level 2   |
| Power consumption                    | 208-240V / 16A / 3kW  |
| Physical protection                  | Locked protecting cover   |
| Cable reel                           | 9 ft. cable length  |
| EV communication                     | IEC 91851 protocol  |
| External communication               | CPL box   |
| Protection rating                    | IP55 and IK7  |
| Security                             | Vehicle to the ground during the charge<br>Self-diagnosis of the Charging Station with automatic switch off in case of default<br>Diagnosis of charge circuit of the vehicle with automatic switch off in case of default<br>Overcharging protection, short circuits, insulation defects by circuit breaker and mandatory external leakage protection |
| Dimensions                           | H 44.3" x W 11.1" x D 12.8"   |
| Weight                               | 177 lbs.  |

IER, Time saver



## IER 983

SELF-SERVICE ENROLLMENT KIOSK FOR CAR SHARING SERVICE  
ALLOWING 24/7 ON-SITE REGISTRATION IN A FEW MINUTES

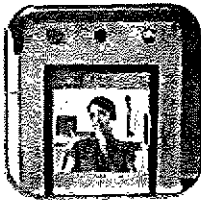



## IER 983 BENEFITS

- Service available 24 hours a day, 7 days a week
- Video conferencing functionality
- Document scanner (for ID, driver's license, etc.)
- Compliant EMV payment ("chip and pin")
- Integrated within IER "Ready To Share" car-sharing offer
- Easy to load supplies
- Issuance of RFID membership cards
- Full registration in less than 15 minutes
- Multi-language user interface
- Distribution and printing of RFID access badges
- Administration and monitoring from a distance
- Clients photography capacity (5 Mpixels)
- Designed for an outdoor environment
- Anti-graffiti coating

## DESCRIPTION

Dramatically increase customer convenience by offering immediate on-site registration to your car-sharing service at any time. The IER Enrollment Kiosk offers a variety of customer interfaces allowing the customer to fully register themselves, with the assistance of a call center operator. After fees are paid, the customer immediately receives an RFID membership card allowing her to access the car sharing vehicle network: full registration in just a few minutes, 24 hours a day, 7 days a week.

## PRODUCT SPECIFICATIONS

|                         |  |
|-------------------------|--|
| Touchscreen             | Industrial 12.1 inch flat TFT, wide angle, LCD color display   |
| Resolution              | XGA 768 x 1024 pixels (vertical)   |
| Touchscreen             | PCTs - projected capacitive  |
| PC                      | Superior industrial PC (no moving parts: without air fan, SATA flash SSD), Windows POSReady or 7   |
| RFID reader             | Intel Atom D525 Dual Core processor, 1.8GHz  |
| RFID badge printer      | ISO 14443 A/B, MiFare DESfire, and Calypso compatible<br>ISO 14443 A/B, MiFare, DESfire, and Calypso compatible<br>Direct thermal printer 200dpi, easy loading |
| Payment module          | Certified: GIE CB MPA V5.2, remote server  |
| Audio conference system | Noise optimization system, Counterpath compatible, waterproof microphones  |
| Document scanner        | Dimension: 5.1" x 8.7", resolution up to 2592 x 1944 pixels  |
| Connectivity            | RJ25 port for modem GSM 3G+ ADSL 2+  |
| Physical protection     | Anti-graffiti coating, steel sheet 2 mm  |
| Dimensions              | W 29.5" x D 14.2" x H 41.7"  |
| Weight                  | 550 lbs.   |

Network  
120/208VAC  
three phases

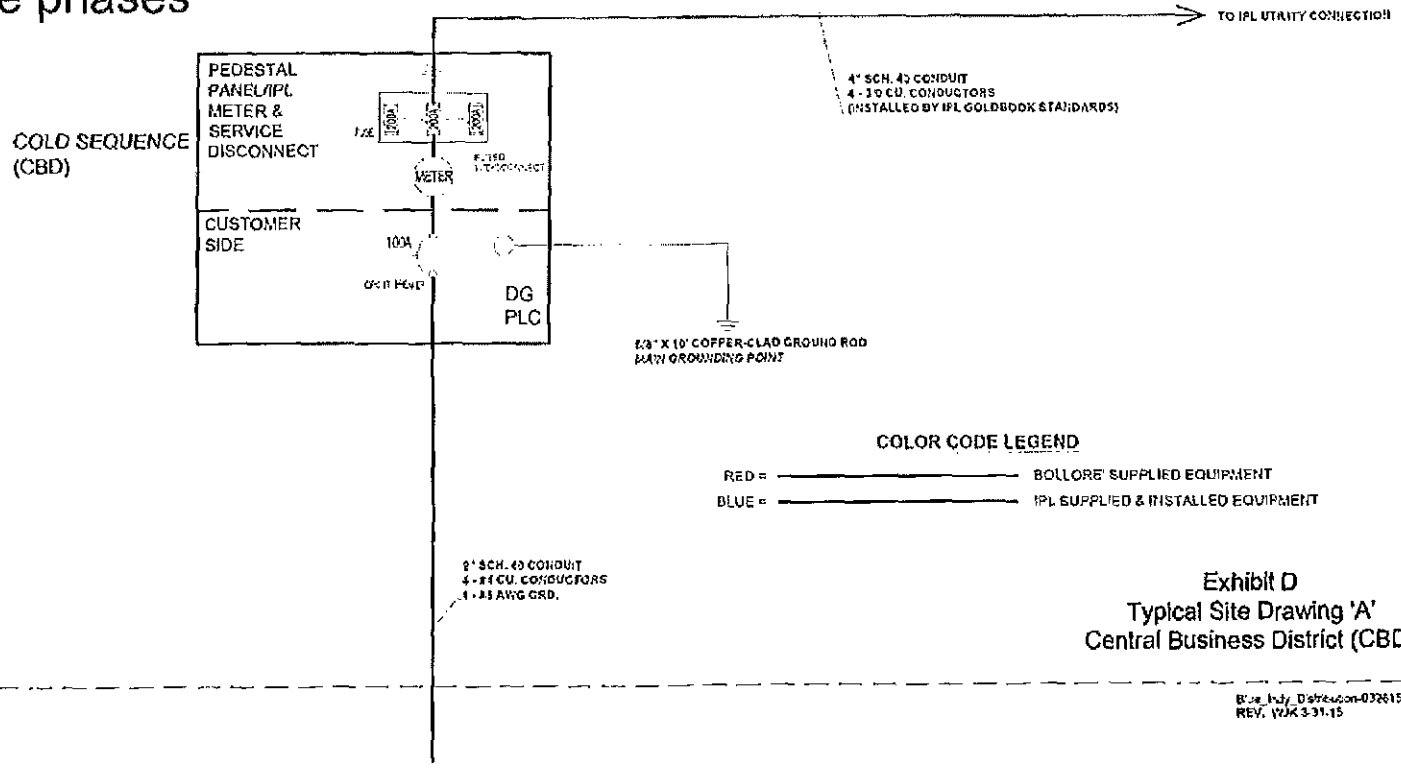

**COLOR CODE LEGEND**  
 RED = \_\_\_\_\_ BOLLORE SUPPLIED EQUIPMENT  
 BLUE = \_\_\_\_\_ IPL SUPPLIED & INSTALLED EQUIPMENT

**Exhibit D**  
 Typical Site Drawing 'A'  
 Central Business District (CBD)

Blue\_Indy\_Distribution-032615.dwg  
 REV. 02/03/15

**Network**  
**120/208VAC**  
**three phases**

HOT SEQUENCE  
 (OUTSIDE CBD)

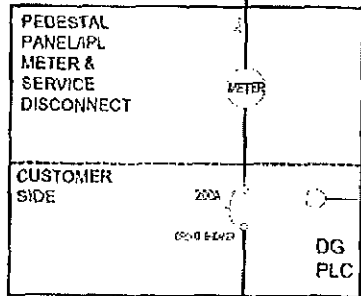

4" SCH. 40 CONDUIT  
 1-40 AL. QUADRUPLX  
 (INSTALLED BY IPL GOLDBOOK STANDARDS)

TO IPL UTILITY CONNECTION

60" X 10" COPPER-CLAD GROUND ROD  
 MAIN GROUNDING POINT

**COLOR CODE LEGEND**

- RED = \_\_\_\_\_ BOLLORE SUPPLIED EQUIPMENT
- BLUE = \_\_\_\_\_ IPL SUPPLIED & INSTALLED EQUIPMENT

2" SCH. 40 CONDUIT  
 4 - #4 CU. CONDUCTORS  
 1 - #8 AWG GRD.

**Exhibit D**  
**Typical Site Drawing 'B'**  
**Non Central Business District**  
**(Non-CBD)**

# Miller Eads

4125 N. Keystone Avenue

Indianapolis, IN 46205

Phone: (317) 545-7101 Fax: (317) 545-4660

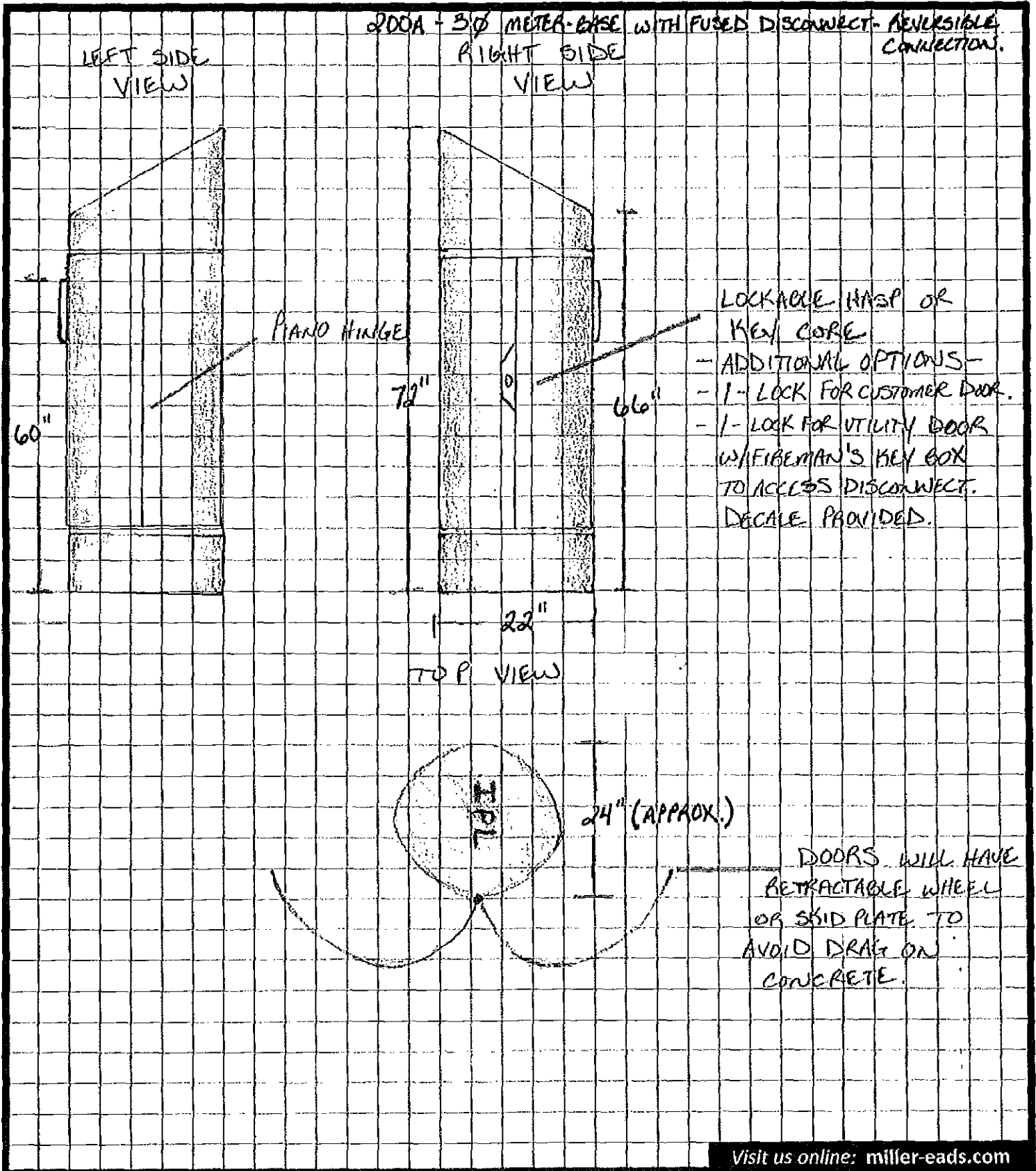

Visit us online: [miller-eads.com](http://miller-eads.com)

PROJECT:

SCALE:

DATE:

BY:

DWG NO:

# Miller Eads

4125 N. Keystone Avenue

Indianapolis, IN 46205

Phone: (317) 545-7101 Fax: (317) 545-4660

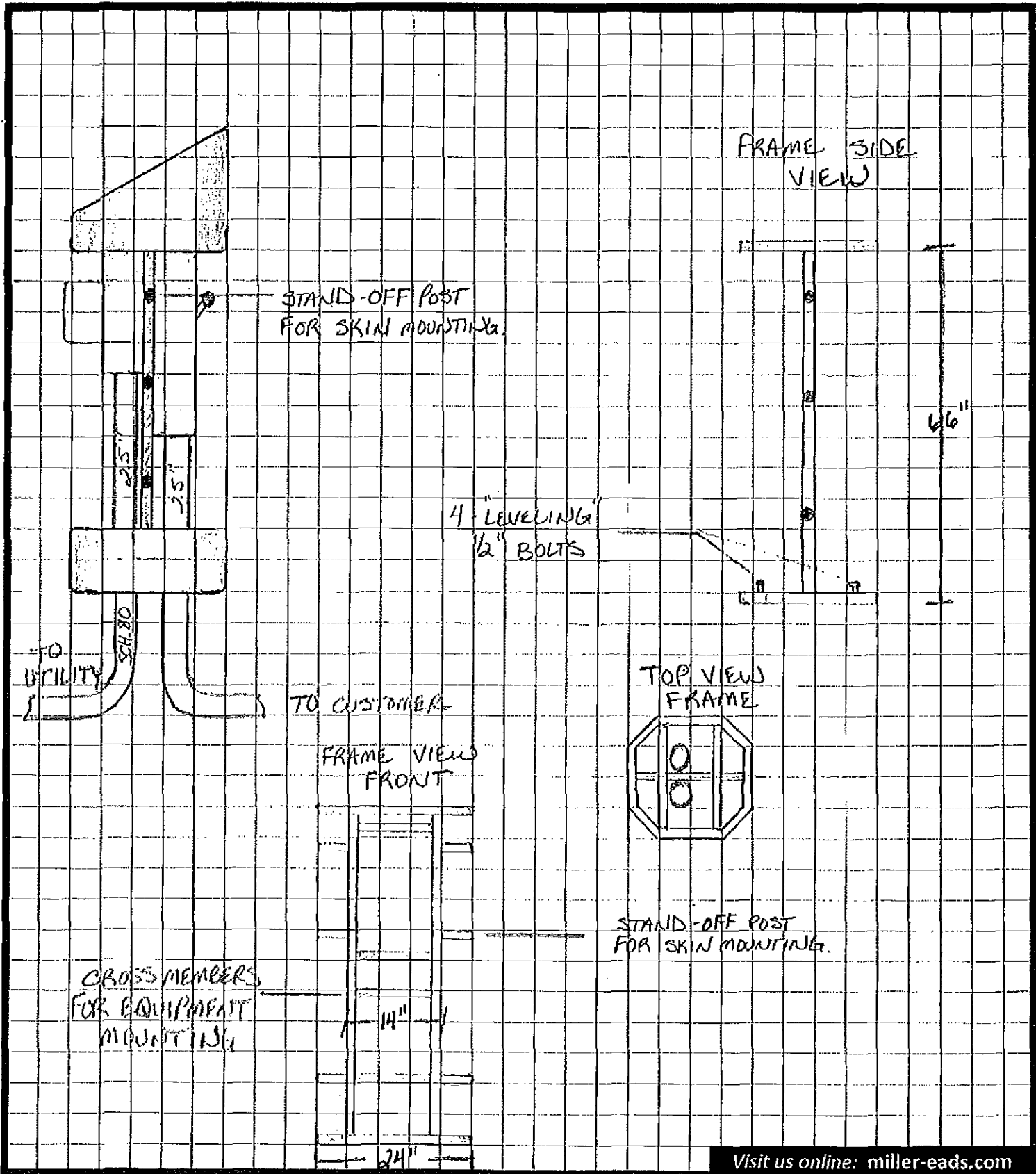

Visit us online: [miller-eads.com](http://miller-eads.com)

PROJECT:  SCALE:  DATE:  BY:  DWG NO:

**EXHIBIT E**  
**ESTIMATED BUDGET FOR IPL'S COSTS**



Revised 3/23/15

**Budget for IPL's Extension Costs for BlueIndy Project**

| Cost Element  | Average \$ per site | Line Extension<br>(190 sites) |
|---|---------------------|-------------------------------|
| <b>Site Type A - Central Business District ("CBD")</b>  |                     |                               |
| IPL - Engineering & Construction                        | \$ 12,000           | \$ 1,140,000                  |
| <b>Site Type B - Non-CBD General Distribution</b>       |                     |                               |
| IPL - Engineering & Construction                        | \$ 17,000           | \$ 1,615,000                  |
| <b>Administrative Expenses</b>                          |                     |                               |
| Easement Procurement (15%) of CBD sites @ \$25K each    |                     | \$ 356,250                    |
| Easement Procurement (60%) of non-CBD sites @\$10K each |                     | \$ 570,000                    |
| <b>Approximate Total</b>                                |                     | \$ 3,681,250                  |
|   | rounded estimate    | \$3.7 million                 |

These costs are based on an analysis of the first 25 sites and an assumption that half of the sites will be within the Indianapolis CBD and the other half will be outside of it. The actual costs may be higher or lower than these estimates. Cost estimate reflects installation of 190 locations. Additional locations will be installed to the extent funds remain within the \$3.7M total.

**EXHIBIT F**  
**PARENT GUARANTY**

Bluecarsharing SAS

23 rue du Professeur Victor Pauchet  
F-92420 VAUCRESSON  
FRANCE

To: Indianapolis Power & Light Company

Date: \_\_\_\_\_, 2015

Dear Sir/Madam,

We, BluecarSharing a private limited company ("Société par Actions Simplifiée") registered in France (Company registration number 528.872.625 RCS NANTERRE) with a capital of 10,000.00 €, whose registered office is at 23 rue du Professeur Victor Pauchet, Vaucresson, 92420, France, ("the Guarantor"), understand that the City of Indianapolis, Indiana ("City") has entered into a contract titled "ELECTRIC VEHICLE SHARING CONCESSION AGREEMENT" on April 8, 2014 with BlueIndy, LLC, ("the Operator") ("the Original Agreement"), as amended by that certain First Amendment dated October 1, 2014 ("the First Amendment") and that certain Second Amendment to Electrical Vehicle Sharing Concession Agreement effective as of February 27, 2015 ("the Second Amendment"), which has been amended and restated by an Amended and Restated Electric Vehicle Sharing Concession Agreement dated as of March \_\_, 2015 (as so amended and restated, "the Agreement") on the condition that the obligations of the Operator under the last paragraph of Section 2.03(a)(i) and Section 4.03 of the Agreement be guaranteed by Guarantor. We further understand that, until the Expiration Date (as defined below), Indianapolis Power & Light Company, Inc., ("IPL") is a third party beneficiary to the last paragraph of Section 2.03(a)(i) and Section 4.03 of the Agreement as provided in Section 12.05 of the Agreement.

The Operator is our indirect subsidiary, and we represent and warrant to IPL that this description of our relationship with/to the Operator is true and accurate in all material respects.

WE HEREBY AGREE AND UNDERTAKE with IPL as follows:

- (a) We unconditionally guarantee the due and punctual payment by the Operator to IPL of all payments, sums, liabilities, awards, losses, damages, costs, charges and expenses that may be or become due and payable to IPL under or arising out of Section 4.03 of the Agreement in accordance with its terms or otherwise including by reason or in consequence, of any such default on the part of the Operator when and as the same shall become due for payment. For the avoidance of doubt, the Operator's obligation to pay IPL under Section 4.03 of the Agreement does not arise until the Agreement is terminated by the City pursuant to Section 4.02(c) of the Agreement during the first five years of the Initial Term of the Agreement (the "Guaranty Condition").
  
- (b) We unconditionally guarantee the due and punctual payment by the Operator to IPL of

the Liquidated Damages (as defined in 2.03(a)(i) of the Agreement) that may be or become due and payable to IPL under or arising out of the last paragraph of Section 2.03(a)(i) of the Agreement in accordance with its terms when and as the same shall become due for payment and after expiration of the Cure Period (as defined in Section 2.03(a)(i) of the Agreement). For the avoidance of doubt, the Operator's obligation to pay IPL shall arise immediately upon a Failure (as defined in Section 2.03(a)(i) of the Agreement) and expiration of the Cure Period and shall not be subject to, or conditioned upon, the Guaranty Condition which shall have no applicability to Guarantor's obligations under this subparagraph.

- (c) As a separate and primary obligation we unconditionally guarantee to IPL that in the case of default by the Operator in making any of the payments set out in paragraph (a) or (b) above, we shall, on demand, pay all sums as if we instead of the Operator were the primary obligor.
- (d) This Guaranty shall remain in full force and effect until the Expiration Date (as defined in Section 3 below).
- (e) Any demand or other notice made by IPL under this Guaranty shall be duly made if sent by first class recorded delivery (or other registered delivery) post to us.
- (f) After a Failure (as to the obligations set forth in Subparagraph (b) of this Paragraph), or after the satisfaction of the Guaranty Condition (as to the obligations set forth in Subparagraph (a) of this Paragraph), IPL shall be entitled to enforce this Guaranty, as to the applicable obligations of Operator set forth in Subparagraphs (a) and (b) of this Paragraph, without first notifying the Operator of any default or taking any proceedings or demanding upon, enforcing or exhausting any right or remedy against the Operator or any other person or taking any action to enforce any other security, bond or guarantee held by IPL or making or filing any claim in a bankruptcy, liquidation, administration or insolvency of the Operator or any person.
- (g) If any sum due or purportedly due under this Guaranty is not or would not be recoverable under a guarantee for any reason whatsoever, whether or not known to IPL, such sum shall still be recoverable from us as a sole principal debtor upon the terms of this Guaranty.

**PROVIDED THAT:**

1. We shall be under no greater obligation or greater liability under this Guaranty than we would have been under the Agreement if we had been named as the Operator in the Agreement.
2. Notwithstanding any other provision of this Guaranty, our aggregate liability under this Guaranty shall not exceed FOUR MILLION US DOLLAR (\$4,000,000.00 USD), plus all costs and expenses (including reasonable attorneys' fees) incurred by IPL in connection with the enforcement of this Guaranty awarded in connection with any Proceeding instituted or shall be included in any settlement or other payment of the disputed



amounts.

3. Notwithstanding any other provision of this Guaranty, this Guaranty shall automatically and without any notification terminate five (5) years after the Effective Date of the Agreement ("Expiration Date"), unless, on such Expiration Date there exists any breach or default by Operator under the Agreement for which the Agreement could be terminated under Section 4.02 (c) and for which the Operator has received written notice of such default or breach and thereof if the same is not ultimately cured within the prescribed cure periods, in which event, the Expiration Date shall be extended until the ninetieth (90<sup>th</sup>) day after the expiration of the applicable cure period.
4. Our obligations hereunder are those of primary obligor with respect to all payments, sums, liabilities, awards, losses, damages, costs, charges and expenses that may be or become due and payable to IPL under or arising out of the last paragraph of Section 2.03(a)(i) and Section 4.03 of the Agreement and shall remain in full force and effect and shall not be terminated, reduced, discharged or otherwise affected by:
  - (a) Any alteration or variation to the terms of the Agreement made by agreement between the City and the Operator (including, without limitation, any increase in the Operator's obligations under the Agreement or any alteration in the extent or nature or sequence or method or timing of the Services to be carried out under the Agreement) or any novation of the Agreement (in whole or in part);
  - (b) Any time being given to the Operator or any other indulgence, waiver, concession, forbearance or forgiveness to the Operator (whether express or by conduct) or any other thing done, omitted or neglected to be done under the Agreement;
  - (c) Any other bond, security or guarantee now or hereafter held by IPL for all or any part of the obligations of the Operator under the Agreement;
  - (d) The release or waiver of any such bond, security or guarantee referred to in paragraph 4(c) above;
  - (e) Any amalgamation, reconstruction or dissolution including, without limitation, winding-up of the Operator;
  - (f) The winding-up, bankruptcy, administration, receivership or insolvency of the Operator;
  - (g) Any legal limitation, disability or incapacity relating to the Operator or discharge by operation of law or any change in the constitution, name or style of the Operator or any other person (whether or not known to IPL);
  - (h) Any total or partial invalidity in, irregularity affecting or unenforceability of, any of the obligations of the Operator under the Agreement;

- (i) The termination or partial termination of the Agreement or the cessation of any Services for any reason or the making of any variation to the Services in accordance with the Agreement;
  - (j) Any claim or enforcement of payment from the Operator or any other person; or
  - (k) Any act or omission which would not have discharged or affected the liability of a sole principal debtor instead of a guarantor or any act or omission, matter or thing which, but for this provision, might operate to exonerate, discharge, reduce or extinguish our liability under this Guaranty.
5. So long as we remain under any actual or contingent liability under this Guaranty, we shall not exercise any right of subrogation or any other right or remedy which we may have against the Operator in respect of any payment made by or sum recovered from us pursuant to or in connection with this Guaranty or prove in any liquidation of the Operator in competition with IPL for any sums or liabilities owing or incurred to us by the Operator in respect of any such payment by or recovery from us or take or hold any security from the Operator in respect of any liability of ours hereunder. We shall hold any monies recovered or security taken or held in breach of this provision in trust for IPL.
6. Prior to the Expiration Date, no termination of the Agreement by the City, other than pursuant to Section 4.02(c) of the Agreement, shall be valid unless IPL consents thereto.
7. Except where prevented from doing so by law, we waive and agree not to enforce or claim the benefit of any and all rights we have or may from time to time have as guarantor under any applicable law which is or may be inconsistent with any provision of this Guaranty, including, without limitation, we hereby expressly waive to the fullest extent permitted by law: (i) notice to the Guarantor of any breach or default by Operator under the Agreement other than the copy of the notice to the Operator given by the City pursuant to Section 4.02(c) of the Agreement (ii) any requirement of diligence and any defense based on a claim of laches; (iii) all defenses which may now or hereafter exist by virtue of any statute of limitations, or of any stay, valuation, exemption, moratorium or similar law, except the sole defense of full and indefeasible payment; (iv) any requirement that Guarantor be joined as a party in any action or proceeding against Operator to enforce any of the provisions of the Agreement; (v) any requirement that Guarantor be involved in any dispute resolution procedures involving the Operator to enforce any of its obligations under the Agreement (including the dispute resolution procedures set forth in the Agreement); (vi) any requirement that IPL mitigate or attempt to mitigate damages resulting from a default by Guarantor hereunder or from a default by Operator under the Agreement; (vii) acceptance of this Guaranty; and (viii) all presentments, protests, notices of dishonor, demands for performance and any and all other demands upon and notices to Operator, and any and all other formalities of any kind, the omission of or delay in performance of which might but for the provisions of this Section constitute legal or equitable grounds for relieving or discharging Guarantor in whole or in part from its irrevocable, absolute and continuing obligations hereunder, it being the intention of Guarantor that its obligations hereunder shall not be discharged except by payment and performance and then only to the extent thereof.

8. If after receipt of any payment of, or the proceeds of any collateral for, all or any part of the liabilities of Guarantor hereunder, the surrender of such payment or proceeds is compelled or volunteered to any person because such payment or application of proceeds is or may be avoided, invalidated, recaptured, or set aside as a preference, fraudulent conveyance, impermissible set-off or for any other reason, whether or not such surrender is the result of: (i) any judgment, decree or order of any court or administrative body having jurisdiction, or (ii) any settlement or compromise of any claim as to any of the foregoing with any person (including Operator), then the liabilities, or part thereof affected, shall be reinstated and continue and this Guaranty shall be reinstated and continue in full force as to such liabilities or part thereof as if such payment or proceeds had not been received, notwithstanding any previous cancellation of any instrument evidencing any such liabilities or any previous instrument delivered to evidence the satisfaction thereof. The provisions of this Section shall survive the termination of this Guaranty and any satisfaction and discharge of Operator by virtue of any payment, court order or any Federal, state or local law.
9. This Guaranty is irrevocable.
10. This Guaranty, executed and delivered as a deed, is governed by and shall be construed in accordance with the law of the State of Indiana in the United States of America.

Guarantor hereby irrevocably submits to the jurisdiction of any United States Federal court sitting in the Southern District of Indiana over any action or proceeding arising out of or relating to this Guaranty, and Guarantor hereby irrevocably agrees that all claims in respect of such action or proceeding may be heard and determined in such federal court. Guarantor agrees that a final judgment in any such action or proceeding shall be conclusive and may be enforced in other jurisdictions by suit on the judgment or in any other manner provided by law. Guarantor further waives any objection to venue in Indiana and any objection to an action or proceeding in Indiana on the basis of forum non-conveniens. Guarantor further agrees that any action or proceeding brought against IPL shall be brought only in the United States Federal courts sitting in the Southern District of Indiana. Nothing herein shall affect the right of IPL to bring any action or proceeding against the Guarantor or its property in the courts of any other jurisdictions.

11. For the purposes of this Guaranty we hereby appoint Mr. Michael Millikan of Ice Miller LLP to accept service of process on our behalf, and service of Mr. Michael Millikan shall be deemed to be good service on us; and we hereby irrevocably agree not to revoke or terminate such appointment without IPL's prior written consent.
12. IPL shall be entitled to assign the benefit of this Guaranty in whole or in part to any affiliate or to any purchaser of all or substantially all of the assets of IPL or any division of IPL. Guarantor shall not assign the benefit and/or delegate the burden of this Guaranty in whole or in part or enter into any transaction which would result in any of those benefits and/or burdens passing to another person.
13. Guarantor agrees to pay on demand reasonable attorneys' fees and all other costs and expenses which IPL, their affiliates, representatives, successors and assigns may incur in

the enforcement of this Guaranty and which are awarded in connection with any Proceeding instituted or shall be included in any settlement or other payment of the disputed amounts. No terms or provisions of this Guaranty may be changed, waived, revoked or amended without IPL's prior written consent. No course of prior dealing among the parties, no usage of trade, and no parole or extrinsic evidence of any nature shall be used to supplement, modify or vary any of the terms hereof. There are no conditions to the full effectiveness of this Guaranty.

14. If any provision (in whole or in part) of this Guaranty is found by any court, tribunal, administrative body or authority of competent jurisdiction to be wholly or partly illegal, invalid or unenforceable then that provision shall, to the extent required, be severed from this Guaranty and shall be ineffective, without, so far as is possible, modifying any other provision of this Guaranty and this shall not affect any other provisions of this Guaranty which shall remain in full force and effect.
15. GUARANTOR ACKNOWLEDGES THAT IT HAS BEEN ADVISED BY COUNSEL OF ITS CHOICE WITH RESPECT TO THIS GUARANTY AND THAT IT MAKES THE FOLLOWING WAIVER KNOWINGLY AND VOLUNTARILY. GUARANTOR IRREVOCABLY WAIVES TRIAL BY JURY IN ANY COURT AND IN ANY SUIT, ACTION OR PROCEEDING OR ANY MATTER ARISING IN CONNECTION WITH OR IN ANY WAY RELATED TO THE TRANSACTIONS CONTEMPLATED BY THIS GUARANTY, THE AGREEMENT OR ANY DOCUMENTS RELATED THERETO (INCLUDING CONTRACT CLAIMS, TORT CLAIMS, BREACH OF DUTY CLAIMS, AND ALL OTHER COMMON LAW OR STATUTORY CLAIMS) AND THE ENFORCEMENT OF ANY OF OPERATOR'S RIGHTS AND REMEDIES.
16. GUARANTOR HEREBY KNOWINGLY AND VOLUNTARILY AGREES THAT THE RESOLUTION OF ANY DISPUTE THAT ARISES UNDER THIS GUARANTY SHALL NOT BE SUBJECT TO THE DISPUTE RESOLUTION PROCEDURES SET FORTH IN THE AGREEMENT.
17. The undersigned are duly elected officers and/or directors of Guarantor with full power and authority to execute and deliver this Guaranty and upon execution hereof this Guaranty shall be valid, binding and enforceable against Guarantor in accordance with its terms.
18. This Guaranty amends and restates that certain Guaranty executed by Guarantor on April 8, 2014 in its entirety. Guarantor, upon execution and delivery of this Guaranty, ratifies and reaffirms that all of its obligations under the original guaranty being amended and restated hereby continue in full force and effect and are guaranteed under this Guaranty.

Executed as a Deed and delivered the day and year written above.

acting by its President

\_\_\_\_\_  
President

in the presence of :

Witness Signature.....

Witness Name : Laurent CZAJKOWSKI  
Witness Address : C/O BLUECARSHARING SAS  
23 rue du Professeur Victor Pauchet  
92420 Vaucresson  
France

## EXHIBIT G

### MAP OF IPL ASSIGNED SERVICE TERRITORY AS OF EFFECTIVE DATE



### Service Territory Coverage Area

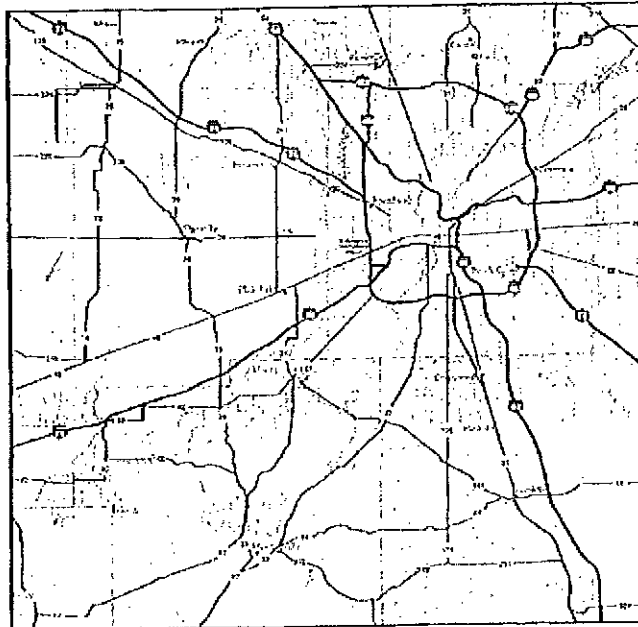

Designates IPL Service Territory

This material is furnished for general information only. Any user of this material assumes complete responsibility for its use and shall be held liable to InterNorth and InterNorth Power & Light Company for any claims or other actions for damages that in any way may result from any use of this material. The material is for reference only and is loaned for a limited time only use, for the company requesting the information for the specific project. Duplication or further copying of this electronic or paper material is strictly prohibited without written permission from InterNorth Power & Light Co. and remains the sole property of said company. IPL material shall be returned to IPL upon request.

**EXHIBIT H**  
**ESCROW AGREEMENT**

This Escrow Agreement (the "Agreement") is executed this \_\_\_\_ day of \_\_\_\_\_, by and among BlueIndy, LLC (the "Company"), the City of Indianapolis, on behalf of the Mayor's Office (the "City"), and \_\_\_\_\_ (the "Escrow Agent").

**1. Definitions.**

**Court Order** shall mean any order, judgment, or decree of a court having jurisdiction.

**Defense Costs** shall mean all costs and expenses (including, without limitation, reasonable attorneys' fees) incurred by Escrow Agent in connection with any claim or action arising out of a disbursement of Escrowed Funds.

**Disbursement Request** shall have the meaning ascribed to such term in Section 4.

**Electric Vehicle Agreement** shall mean that certain Amended and Restated Electric Vehicle Sharing Concession Agreement executed by and among the Company and the City and dated \_\_\_\_\_, 2015.

**Escrow** shall mean the escrow created pursuant to this Agreement.

**Escrow Account** shall mean an escrow account maintained with Escrow Agent, from which disbursements shall be made by Escrow Agent to Company pursuant to this Agreement.

**Escrowed Funds** shall mean, at any given time, the funds on deposit in the Escrow Account.

**Interpleader Action** shall mean the interpleading by Escrow Agent of the Escrowed Funds into court.

**Location** shall have the meaning ascribed to such term in the Electric Vehicle Agreement.

**Relief Costs** shall mean all costs and expenses (including, without limitation, reasonable attorneys' fees) incurred by Escrow Agent in connection with an Interpleader Action.

**2. Escrow Agent.** Escrow Agent has been appointed by the City to administer the Escrow, and the City agrees to pay all costs associated with such administration. Escrow Agent agrees to: (a) act in the capacity of an escrow agent; (b) comply with the terms and conditions of this Agreement; and (b) satisfy its obligations under this Agreement.

**3. Escrowed Funds.** As expeditiously as possible but no later than September 1, 2015, the City shall deposit Six Million Dollars \$6,000,000.00 into the Escrow Account. Upon deposit, such funds shall become Escrowed Funds. Any interest earned on the Escrowed Funds shall be added to, and become part of, the Escrowed Funds. The deposit of the Escrowed Funds by the City: (a) shall be permanent and irrevocable; and (b) may not be set aside, or "unwound", by any party on any basis or for any reason. The Escrowed Funds may be disbursed only as expressly set

forth in this Agreement or any written amendment hereto executed by each of the Company and City.

**4. Disbursements.**

(a) Reimbursement. For each Location that is put in service and operated by the Company in accordance with the terms and conditions of the Electric Vehicle Agreement, the Company shall be reimbursed from the Escrowed Funds a fixed amount of \$100,000.00.

(b) Disbursements

(i) To receive reimbursement, the Company shall deliver to the Escrow Agent a written request, together with the following information (collectively, the "Disbursement Request"): (A) a list of Locations for which reimbursement is requested; (B) the total amount of Escrowed Funds being requested, which shall be determined by multiplying: (1) the number of Locations for which reimbursement is requested; by (2) \$100,000.00; and (C) a signed statement from the Company certifying that: (1) each listed Location has been put into service, and currently is being operated, by the Company in accordance with the terms and conditions of the Electric Vehicle Agreement; and (2) the Company has not previously received a disbursement of Escrowed Funds for any of the Locations set forth on the list delivered to the Escrow Agent.

(ii) Within ten business days after the Escrow Agent receives all of the information required in the definition of Disbursement Request, the Escrow Agent shall disburse to the Company Escrowed Funds in the amount set forth in the Disbursement Request; provided that, if the Escrow Agent determines that the Disbursement Request does not contain all of the required information, then the Escrow Agent promptly shall deliver to the Company written notice specifying the information that is missing. If the Disbursement Request is received prior to the deposit by the City of Escrowed Funds in the Escrow Account, the Escrow Agent shall disburse to the Company within 10 days of receipt of such funds in the Escrow Account.

(iii) For purposes of clarity, so long as Escrow Agent determines that it has received all of the information required in the definition of Disbursement Request, no notice to, or consent by, City to a disbursement shall be required in connection with a disbursement of Escrowed Funds to the Company

(iv) No disbursements of Escrowed Funds shall be made to the City.



(c) **Frequency.** Disbursements of Escrowed Funds to Company shall not be made more frequently than monthly.

**5. Responsibility.** If the Escrow Agent disburses the Escrowed Funds in accordance with the terms and conditions of this Agreement, then Company and the City shall indemnify and hold harmless Escrow Agent from and against the Defense Costs, to the extent that the Defense Costs are not: (a) to be paid by any other party pursuant to any Court Order; and/or (b) defrayed otherwise by any other party. Such indemnity shall not extend to any claim or action arising out of any failure of Escrow Agent to comply with the terms and conditions of this Agreement. As between Company and the City, the party that does not prevail with respect to the claim or action, as determined by the court in which such claim or action is commenced, shall bear full responsibility for the Defense Costs. Upon written notice to Company and the City at least thirty (30) days in advance, Escrow Agent shall be entitled to reimburse itself for Defense Costs out of the Escrowed Fund.

**6. Interpleader.** If: (a) Escrow Agent has a dispute with Company concerning the disbursement of the Escrowed Funds; and (b) that dispute is not resolved within thirty (30) days after the nature, extent, and specifics of the dispute are identified in a written notice delivered by Escrow Agent to Company; then Escrow Agent, in its sole discretion, may pursue an Interpleader Action. If Escrow Agent pursues an Interpleader Action, then the Company and the City shall indemnify and hold harmless Escrow Agent from and against the Relief Costs, to the extent that the Relief Costs are not: (a) to be paid by any other party pursuant to any Court Order; and/or (b) defrayed otherwise by any other party. Upon written notice to the City and the Company at least thirty (30) days in advance, Escrow Agent shall be entitled to reimburse itself for Relief Costs out of the Escrowed Funds.

**7. Release.** Escrow Agent is authorized to disregard, in its sole discretion, any and all oral or written notices and demands delivered by Company, City, or any other party other than those written notices and demands for which this Agreement provides; provided that Escrow Agent is obligated to comply with: (a) any and all notices and demands made timely and in accordance with the terms and conditions of this Agreement; and (b) any Court Orders. If Escrow Agent complies with: (a) any timely notice or demand in accordance with the terms and conditions of this Agreement; or (b) any Court Order; then Escrow Agent shall not be liable to Company, the City, or any other party by reason of such compliance, notwithstanding: (a) any subsequent notice or demand of a party; and/or (b) that any such Court Order subsequently is: (i) held to have been entered without jurisdiction; or (ii) reversed, modified, annulled, set aside, or vacated.

**8. Third Party Claims.** Until the Escrowed Funds have been disbursed in full, the Escrowed Funds: (a) are agreed to be the property of Escrow Agent, subject to the terms and conditions of this Agreement; and (b) shall not be: (i) subject to any claims or demands of any other party; (ii) subject to execution or levy; or (iii) otherwise available to anyone other than Company, and then only upon compliance with the terms and conditions of this Agreement; provided that, in addition to all other rights and interests hereunder, Company shall be deemed to have a lien upon the Escrowed Funds.

**9. Termination of Escrow.** The Escrow shall terminate upon the sooner of: (a) the date on which all Escrowed Funds have been disbursed to Company in accordance with the terms and



With a copy to:

Ice Miller LLP  
One American Square, Suite 2900  
Indianapolis, Indiana 46282-0200  
Attention: Michael E. Millikan

And to Escrow Agent:

[BUSINESS NAME]  
[AGENT NAME]  
[ADDRESS]  
[CITY, STATE]

Except as otherwise provided in this Agreement, notice shall not be given by facsimile or electronic mail. Any party may change its address or other contact information for notice by giving notice to each other Party in accordance with the terms of this Section.

**12. Miscellaneous.** Subject to Section 10, this Agreement shall inure to the benefit of, and be binding upon, Company, City, and Escrow Agent, and their respective successors and assigns. No waiver of any term or condition of this Agreement by any of Company, City, or Escrow Agent shall be deemed to be a future waiver of such term or condition. The invalidity, illegality, or unenforceability of any one or more of the terms and conditions of this Agreement shall not affect the validity, legality, or enforceability of the remaining terms and conditions hereof. This Agreement shall be governed by, and construed in accordance with, the laws of the State of Indiana. This Agreement may be executed in counterparts, each of which shall be deemed to be an original.

IN WITNESS WHEREOF, Company, CITY, and Escrow Agent have executed this Disbursement Agreement as of the date set forth above.

**Company**

By: \_\_\_\_\_

Printed: \_\_\_\_\_

Title: \_\_\_\_\_

**City of Indianapolis,**

on behalf of the Mayor's Office

By: \_\_\_\_\_

Printed: \_\_\_\_\_

Title: \_\_\_\_\_

**Escrow Agent**

By: \_\_\_\_\_

Printed: \_\_\_\_\_

Title: \_\_\_\_\_

EXHIBIT I  
IPL's WORK

The following shall constitute IPL's Work. IPL shall:

- a) Participate in meetings with the City, the Company, their respective agents, and property owners as necessary to help the Company select Locations and agree on logistics as necessary prior to issuance of a Notice to Proceed and participate in the Location assessments after a Notice to Proceed is issued;
- b) Perform the work described in paragraph (f)(ii) and paragraph (f)(iii) below to extend electric service terminated at a meter installed and owned by IPL at the specific location determined by IPL within the Perimeter (the "Meter Location") after reviewing the Company's proposed Meter Location and Perimeter identified in each Notice to Proceed. IPL's services will include the items identified in the column named "IPL" in Item 8 of Exhibit C to this Agreement;
- c) Participate in project planning with the City and the Company and, at the request of the City:
  - i. Identify any utility easements IPL currently holds on or in the vicinity of proposed Locations within five (5) business days of the request of the City or the Company; and
  - ii. Perform the requisite engineering study and survey for proposed Locations to determine whether any additional utility easements are required for the installation of the line extensions at such Locations;
  - iii. Use reasonable efforts to obtain the grant of an easement on IPL's standard utility easement form from, as applicable, the owner of the Location and adjacent property owner or owners; provided that the City acknowledges that IPL does not warrant or represent that it can secure such easements; and
  - iv. Establish a high-level and nonbinding budget for the work associated with each location and communicate the same to the Company within 8 business days of receipt of a Notice to Proceed.
- d) Obtain and maintain all permits and licenses necessary for the performance of the Extension Services (for avoidance of doubt, IPL's obligations under this paragraph (d) shall not include permits and licenses required for work to be performed by the City, the Company, or any other utility or contractor, or any of their respective subcontractors);
- e) If required by Indiana Code 8-1-26-16, contact Indiana Underground Plant Protection Services to identify known underground facilities owned by other utilities at the Locations; for IPL's line extension only;
- f) Extend distribution and service lines to approximately one hundred ninety (190) Locations, either through its own Personnel or through a qualified contractor selected by

IPL, in accordance with paragraph (b) (for the avoidance of doubt, IPL shall have no obligations with regard to the installation of the Charging Stations, the Kiosks or the Location Fixtures beyond extending its distribution and service lines); IPL will extend primary and secondary rated facilities and necessary transformation to provide three-phase, 200 amp, 120/208 v service for each Location (other than the Indianapolis airport, which will likely require larger service) as follows:

- i. IPL has pre-approved meter fittings and specific meter bases in the IPL published Goldbook, as amended from time to time and available at [https://apps.iplpower.com/Goldbook//Goldbook\\_Complete.pdf](https://apps.iplpower.com/Goldbook//Goldbook_Complete.pdf) (the "Goldbook") (example drawings on page GB5-095). Any non-standard meter base design must be submitted to IPL for approval. The pedestal installed at the Company demo site on E. Washington Street is approved to be replicated at additional sites.
  - ii. For the downtown network (CBD) Locations (as described in the Goldbook page GB0-110), the Company will provide and install the service conduit and cable from the freestanding metering pedestal to IPL's vault or manhole. IPL will make connections to the secondary bus and set a meter. The Goldbook (section 300-310) sets forth the specific requirements.
  - iii. For the non-CBD network Locations, IPL will provide trenching services, install the service conduits and service cables and will allow the Company's network provider to install network cable in the trench, if any, created by IPL to extend its electrical service to the meter pedestal following the execution of a joint trench agreement(s) with the Company's network provider(s) and/or the Company as appropriate. IPL and the Company and/or its subcontractor or network provider will coordinate during the weekly status calls described in paragraph (h) the construction activities with the goal for conduit installations to take place prior to closing of trenches. IPL will not delay closing a trench containing conduit past the time that IPL has completed its own electrical extension work for that Location; however, the Parties agree to cooperate to the greatest extent to avoid such an instance. The Parties agree that it is the responsibility of the Company and its network provider to confirm that the network cable is properly installed and the connection has been successfully tested by the time IPL or its subcontractor is ready to cover the conduit and perform any sidewalk/site repair or finish work. The Company's network provider will assume all responsibilities for the Location associated with underground work, including any site restoration, sidewalks, street and ground repair made necessary in the event its network installation work continues after IPL has closed IPL's trench.
- g) Coordinate installation of the meter with the Company's electrical contractor consistent with IPL's customary practices;

- h) Participate in weekly status calls with the City, the Company and the Company's electrical and excavation contractors; and
- i) Provide a monthly budget tracking report showing the number of Locations at which IPL's Work has been completed and IPL's Costs incurred to date. IPL and the Company shall meet and confer monthly in good faith to consider options on how they can make the most cost-effective use of the \$3,700,000 budget with a goal of up to 190 Locations.
- j) IPL acknowledges that the Company will be a tariff customer of IPL and that IPL is obligated to provide service to the Company in accordance with IPL's tariff including Section 23 (Continuity of Supply) of its Rules and Regulations as it exists from time to time.

IPL's Work will be limited as follows:

- a) IPL's obligation to perform the Extension Services is conditioned in part upon IPL's receipt of Notices to Proceed (including Location drawings per Section 2.04(b)(ii)(C) of this Agreement.
- b) IPL's obligation to perform the Extension Services will not extend past December 31, 2016 unless the Parties and the Company agree otherwise in writing. Other than as set forth in the prior sentence, there shall be no expectation nor any requirement for the Extension Services to continue thereafter unless they were begun at least sixty (60) days prior to December 31, 2016. If, notwithstanding the Company's good faith best efforts, the Company is unable to deploy all the Locations contemplated by this Agreement by December 31, 2016, IPL agrees to consider extending that deadline for a period of time on terms and for a duration in IPL's sole discretion.
- c) IPL's funding of IPL's Costs is limited to an amount up to but not to exceed Three Million Seven Hundred Thousand Dollars (\$3,700,000) for approximately 190 Locations and such funding is contingent upon the IURC ARP Order not being modified; provided that upon notice by IPL to the City that the City has breached the IPL Agreement, IPL shall not be required to continue funding IPL's Costs unless the breach has been cured which shall not excuse the City from its obligations to the Company under this Agreement.;
- d) IPL will not perform Extension Services at Locations outside of its then-current Assigned Service Territory, a current map of which is attached hereto as Exhibit G;
- e) IPL will not perform Extension Services at a Location at which IPL does not already have, or cannot reasonably obtain, sufficient utility easements to install the line extensions required for the Location Fixtures at that Location.
- f) The City causing the Company to email IPL (at the same time the Notice to Proceed is sent to the City) each Notice to Proceed to an email address of IPL's choosing. The email address is currently [ipl.blueindy@aes.com](mailto:ipl.blueindy@aes.com) and may be changed by giving

written notice to the City and a copy emailed to the Company. If IPL does not acknowledge receipt of the Notice to Proceed by email to the City, then the City, within one (1) business day of the issuance of the Notice to Proceed, shall give formal notice to IPL of the Notice to Proceed.

2015 SEP 10 PM 4 55